

GRS® Dual Angle Sharpening Fixture

INSTRUCTIONS • 003-570

FIG. 1

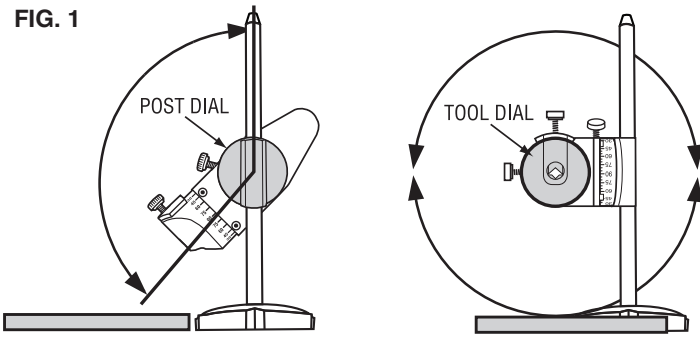

WORN. A face mask should also be worn to prevent breathing wheel dust.

Tools can easily be damaged while grinding. Do not let the tool tip get hot and burn. Burning means the tool metal will turn blue, which takes the temper or hardness out of the tool and it will not hold a cutting edge. To avoid burning the tool, take your time and do not press too hard against the wheel. Have a container of water by your grinder and frequently dip the tool BEFORE it gets warm in your hand.

SUGGESTIONS ON HOW TO PRE-SHAPE THE GRAVER

FIG. 5

90° • 110° • 120° • 130° SQUARE GRAVER

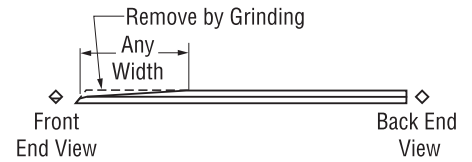

SQUARE BRIGHT CUT GRAVER

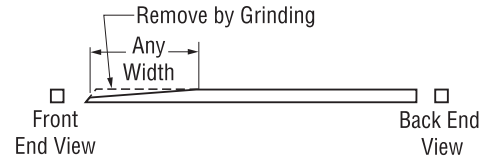

TRADITIONAL GRAVER

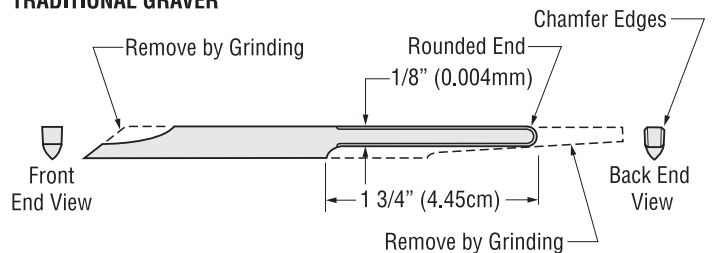

GRAVER LENGTH HINT: Just past the thumb when the tool is in the handpiece or hand handle.

MOUNTING A TOOL IN THE TOOL DIAL

Open and close the jaws by turning the Jaw Thumb Screw. The illustration below shows the correct placement for holding square and traditional gravers. Properly position the graver squarely in the jaws and tighten snugly with your fingers, but do not overtighten. A secure hold prevents tool movement.

FIG. 6

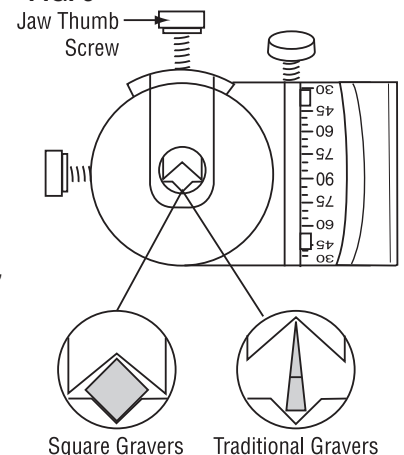

HINT: Use the 0° by the Jaw Thumb Screw when sharpening the FACE ANGLE. Lock the dial into position before inserting a tool. When inserting the tool, make sure its face angle is facing down, away from the Jaw Thumb Screw.

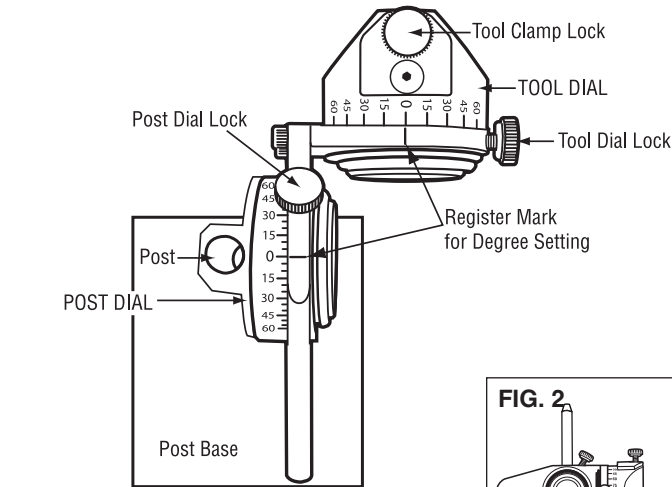

FIG. 2

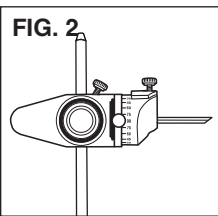
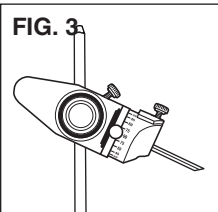

FIG. 3



Set both dials at 0° to the register marks (FIG. 1). Slide the fixture onto the base post and hold it out in front of you. Position the fixture so that it is square to your body and the tool being sharpened is pointing "straight" away from you (FIG. 2). As you change this angle, the position of the fixture will rotate down (FIG. 3).

The TOOL DIAL can turn left or right 360°, but always use one of the 0° as a reference point. After grinding the face angle, turn the tool over (180°) by rotating from reference point 0° to new reference point 0°. Now you can set the angles desired, left and right, from the new 0° reference point.

GETTING THE GRAVER READY TO SHARPEN

Most tools need some type of preparation before sharpening. Shank modification to fit a hand handle or power handpiece, or just shortened to fit your personal needs. GRS Tools offers gravers that are already modified and ready to be sharpened.

FIG. 4

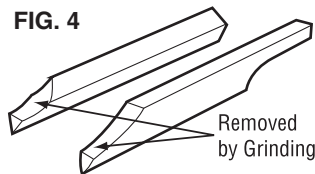

Removal of excess metal from the top/front of the tool tip makes it quicker and easier to re-sharpen (FIG. 4). It also allows a better view of the tip when in use. You will need to use a bench grinder or a Power Hone with a 260 grit wheel. Rough grind with a bench grinder first, then true the surface with the Power Hone if you desire. When using a bench grinder, eye protection MUST BE

Square Gravers in Quick Change holders (**FIG. 7**), must be inserted into the jaws from the back. DO NOT hold tool by the Quick Change holder in the jaw.

Hold **Curved Traditional Graver** (**FIG. 7**) as shown. *NOTE: Because of the tool's curve, you will need to estimate the angle needed to set the face angle.*

90 DEGREE SQUARE GRAVER

With the graver's excess metal removed — see getting the graver ready to sharpen (**FIG. 8**) — you are ready to make the face angle (**FIG. 9**). With the tool mounted, face angle down, and the TOOL DIAL locked at 0°, set the POST DIAL at 45°. This is just an example, you may change face angles to fit your needs. If you are using a square blank graver, start your face angle by using a 260 grit wheel on the Power Hone. Finish the face surface by stepping up to a 600 grit, then a 1200 grit. Once you have finished the face, you will only need to take these steps again if the tip becomes severely damaged. If you're not using a Power Hone, shape the face as close as possible on a bench grinder and finish with this fixture and a stone.

A 15° heel will be used for this example (**FIG. 10**). Set the POST DIAL at 15° and lock it. Rotate the TOOL DIAL halfway around or 180°, go from the top 0° setting until the bottom 0° setting is on top. From the new 0°, tool pointing away from you, turn dial clockwise, until it reads 45° and lock. Sharpen on a ceramic wheel, making the heel about 1/32" long. If you heel on a 1200 grit wheel, use the fixture and stroke the graver a couple times without turning the Power Hone on. After forming this heel, turn the dial counterclockwise, going past the 0° until it reads 45° and lock in position. Finish the heel on this side using the same method. It is important that both heels are the same size and symmetrical.

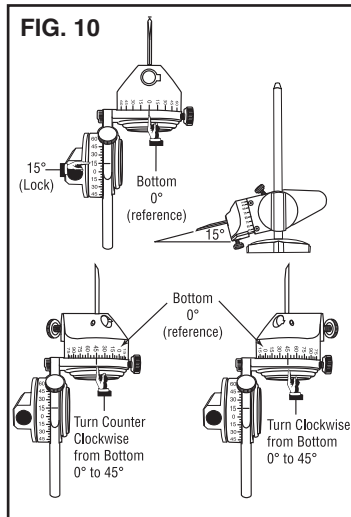
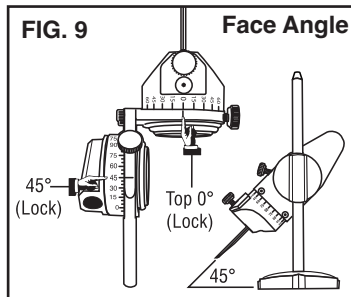
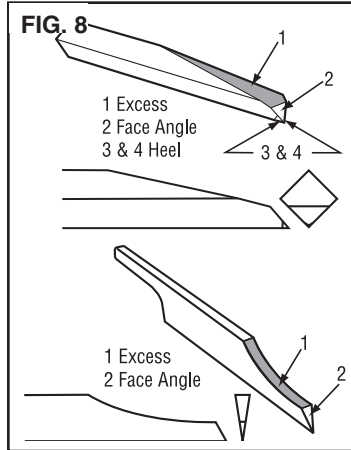
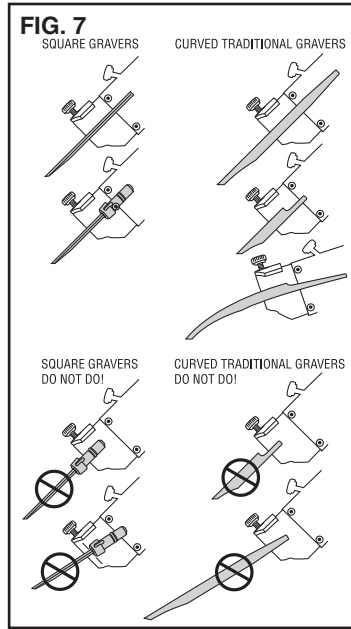

MAKING A 120 DEGREE GRAVER FROM A SQUARE GRAVER

Refer to "SHARPENING A 90° GRAVER", for details. With the graver's excess metal removed (**FIG. 11**) mount the tool face angle down in the TOOL DIAL and lock at 0°. Set the POST DIAL at 45° (or desired face angle) and grind the face (**FIG. 12**). Turning the TOOL DIAL around 180° to reference 0° and change the POST DIAL to 2-1/2° (halfway between 0° and 5°) and lock in position. From reference 0°, rotate dial clockwise to 30° and grind angle (**FIG. 13**). Make this angle grind about 1/2" long. Rotate TOOL DIAL counter clockwise past reference 0° to 30°, lock and grind angle (**FIG. 13**). Make this side the same length as the other side (**FIG. 13**). *TIP: To measure how much you are grinding off, time it or count while it's grinding.* It may be necessary to regrind the other side to make both sides equal. But it is important that the sides are equal and symmetrical.

Make the heel (**FIG. 14**) by changing the POST DIAL to 15° (or desired heel angle). The TOOL DIAL is already at 30° left, so make this heel and rotate TOOL DIAL right, past reference 0° to 30° and make the other heel. The 120° graver is complete.

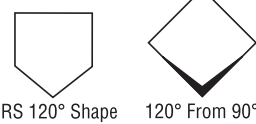

HOW TO MAKE A 110 DEGREE & 130 DEGREE OUT OF A SQUARE GRAVER

Basically, making a 110° or 130° graver is the same as making a 120° graver, just change the TOOL DIAL angle for different side angles.

110° graver (FIG. 13): The side angle POST DIAL is set at 2-1/2°, but set the TOOL DIAL from reference 0° left 35° and make one side, then right 35° from reference 0° to make the other side.

130° graver (FIG. 13): The side angle POST DIAL is set at 2-1/2°, but set the TOOL DIAL from reference 0° left 25° and make one side, then right 25° from reference 0° to make the other side.

How do you figure this angle setting? The sides of a 90° tool mounted in a fixture, dial set at 0°, are 45° from the wheel. Adding all angles: 45° + 45° + 90° = 180° (a flat plane). Using 180° minus (desired tool angle) let's say, 110° = 70°. There are two sides to the tool, so you divide 70° by 2 which equals 35°, the setting to make a 110° graver.

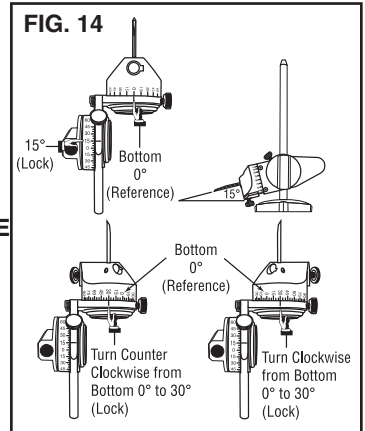
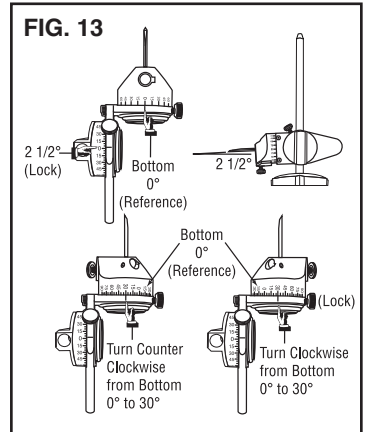
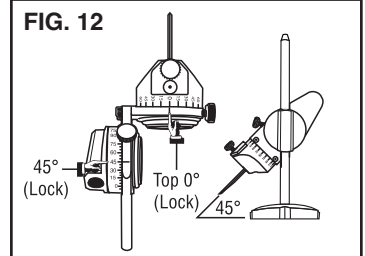
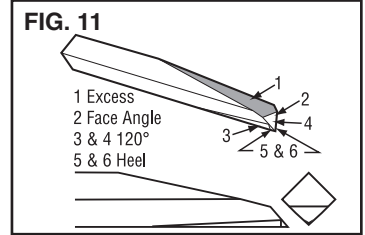

ONGLETTE GRAVER

Very gently, with a very short stroke, make a heel on one side of the tool tip then the other side. Take care not to flatten the point. If using a Power Hone, DO NOT turn it on.

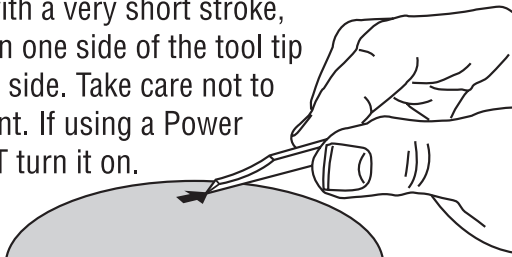

FLAT GRAVER

Use the Dual Angle Fixture to make a heel. MAKE HEEL VERY SMALL! Do NOT turn wheel on.

Make a small radius heel: Hold the tool tip on the wheel or stone while pulling the Dual Angle fixture up the post. This makes a nice even radius.

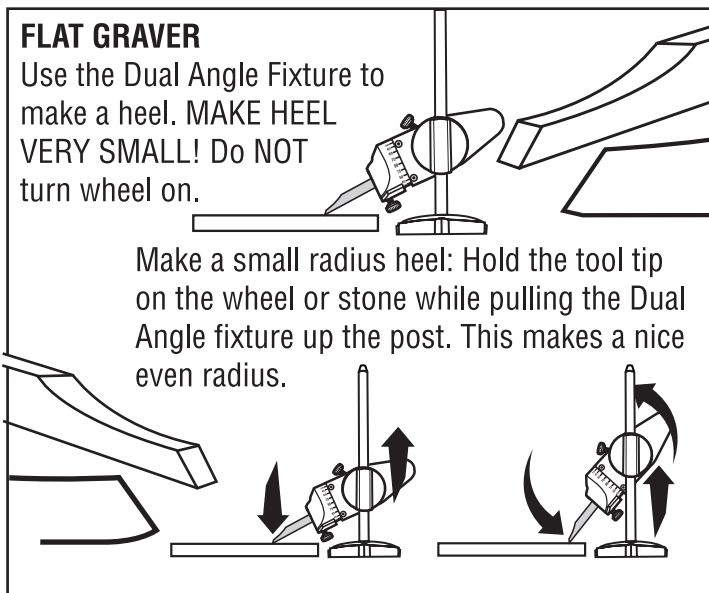

LINE GRAVER

NO HEEL REQUIRED. HINT: Use spray diamond on a piece of leather and pull the tip across it. This cleans and polishes the liners so they make brighter cuts.

Western engravers like to round the front end to shade flower petals!

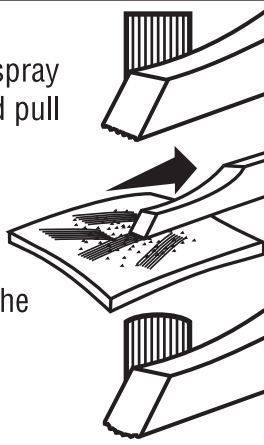

ROUND GRAVER

Carefully hand swipe graver tip on a wheel or stone and make a very small radius heel. Do NOT turn wheel on.

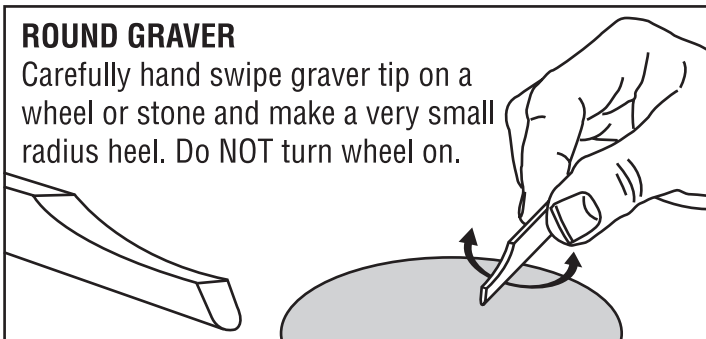

CALIBRATION

Step 1: Loosen the two bolts, about a full turn each, in the lower jaw with a hex wrench. Do not remove.

Step 2: Make sure the bolts are loose enough that you can "wiggle" the lower jaw with your fingers.

Step 3: Insert the small round calibration pin (included with the fixture) and slowly start to turn the thumbscrew to tighten it into the jaws. While turning the thumbscrew, continuously wiggle the lower jaw. This will make the lower jaw "seat" in the proper location on the calibration pin.

Step 4: Once you have the calibration pin seated and snugged down, tighten the lower jaw bolts with the hex wrench. *NOTE: Use the long end of the hex wrench in the bolt head and turn with the short end to prevent overtightening. Overtightening will damage the fixture.*

Step 5: Loosen the "DEGREE" ring with the small hex wrench until you can easily turn the degree ring independently from the jaw head. Now, remove the round calibration pin and replace it with a square graver. A GRS GlenSteel graver will work great.

Step 6: Place a ceramic lap wheel on your Power Hone for a smooth flat surface. *TIP: If you don't have a ceramic lap use a fine grit diamond wheel and turn it up-side-down and use the smooth backside.* Place the dual angle fixture head on the post stand and position the square graver so that a side of it is pressed flat against the wheel. While holding the graver flat, turn the degree ring and register the 45° mark to the center line mark and tighten the degree ring set screw. Now, when you turn the fixture head to 0° or 90° the graver is calibrated and in the correct position.

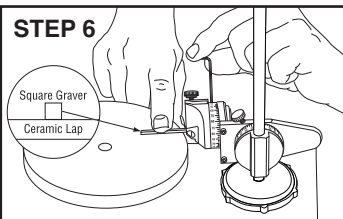
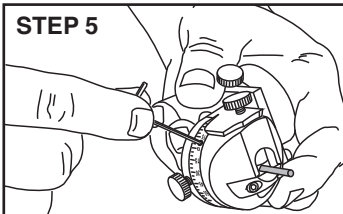
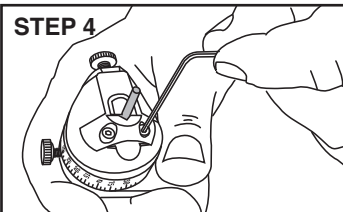
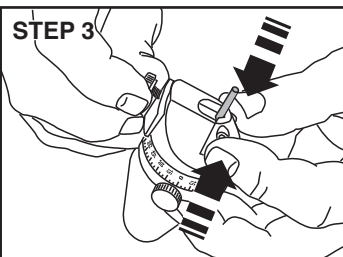
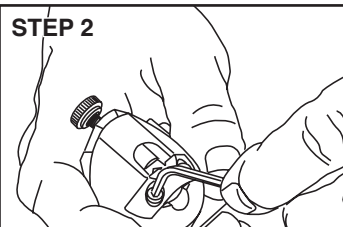
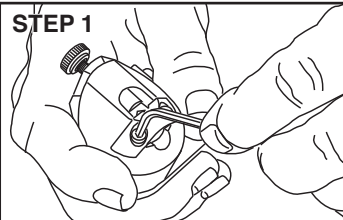

GRS® Dual Angle Sharpening Fixture

PARTS LIST • 003-570

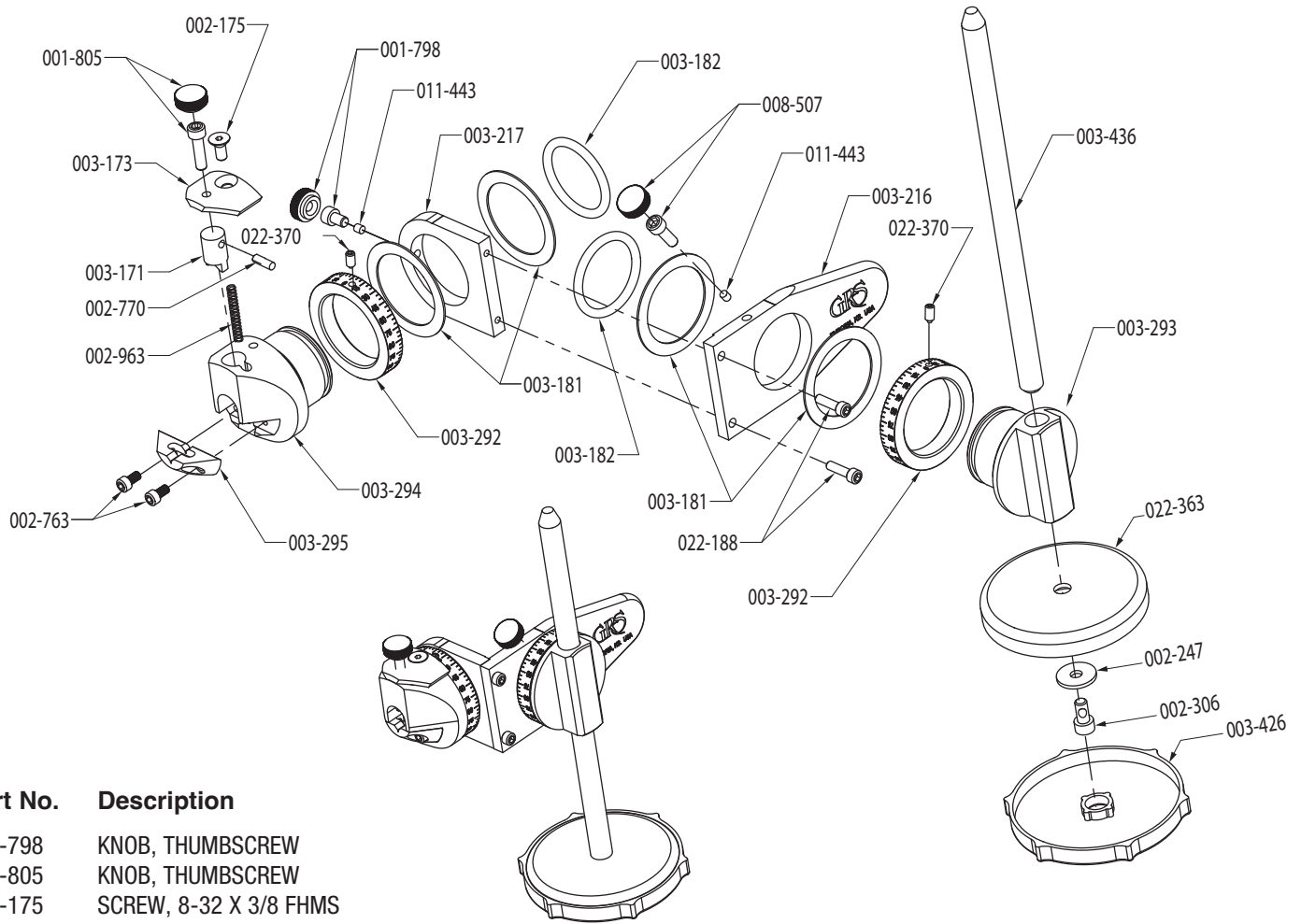

Part No. Description

- 001-798 KNOB, THUMBSCREW
- 001-805 KNOB, THUMBSCREW
- 002-175 SCREW, 8-32 X 3/8 FHMS
- 002-247 WASHER. .191 X .628 X 16 GA
- 002-306 10-32 x .375 SHCS WITH NYLON PATCH
- 002-763 6-32 X 0.25 SHCS BLK
- 002-770 PIN, DRIV-LOK 1/8" x 3/8" TYPE H
- 002-963 SPRING
- 003-171 CLAMP
- 003-173 COVER
- 003-181 PLASTIC WASHER
- 003-182 O-RING
- 003-216 ARM FOR DUAL ANGLE FIXTURE
- 003-217 LEG FOR DUAL ANGLE FIXTURE
- 003-292 DEGREE RING FOR DUAL ANGLE FIXTURE
- 003-293 SLIDING PIVOT FOR DUAL ANGLE FIXTURE
- 003-294 HOLDER BLOCK FOR ADJUSTABLE DEGREE SCALE
- 003-295 LOWER JAW FOR DUAL ANGLE FIXTURE
- 003-426 MAGNET COVER TO REDUCE PULL
- 003-436 EXTENDED LENGTH SHARPENING POST WITH PILOT DIAMETER
- 008-507 KNOB, THUMBSCREW
- 011-443 NYLON PILL
- 022-188 6-32 x 0.500" SHCS BLK
- 022-363 POT MAGNET (CERAMIC)
- 022-370 NYLON TIPPED SET SCREW FOR DEG DIAL

GLENDO LLC

900 Overlander Road • Emporia, KS 66801 USA
 800-835-3519 • 620-343-1084 • Fax: 620-343-9640
 grs@grstools.com • grs.com
 Last Updated: 2025-03-06