



Monarch[®] AT Handpiece

INSTRUCTIONS

INSTRUCTIONS • #005-921-AT

#005-921-AT Compatible GRS[®] systems include: GraverMach[®] AT, or an Airtact Control System (#004-935) connected to a GraverMax[®] G8, GraverMach[®], GraverMax[®] SC, GraverSmith[®], or Classic GraverMax[®] / GraverMate[®] (with Airtact Filter Hook Up Kit) machines.

WARNING

Monarch AT Handpiece is factory set and ready for use.

No adjustments are necessary before use.

Tampering with screw on base will compromise handpiece performance and usability.

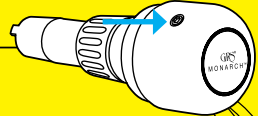

Connect Airtact[®] Handpiece(s)

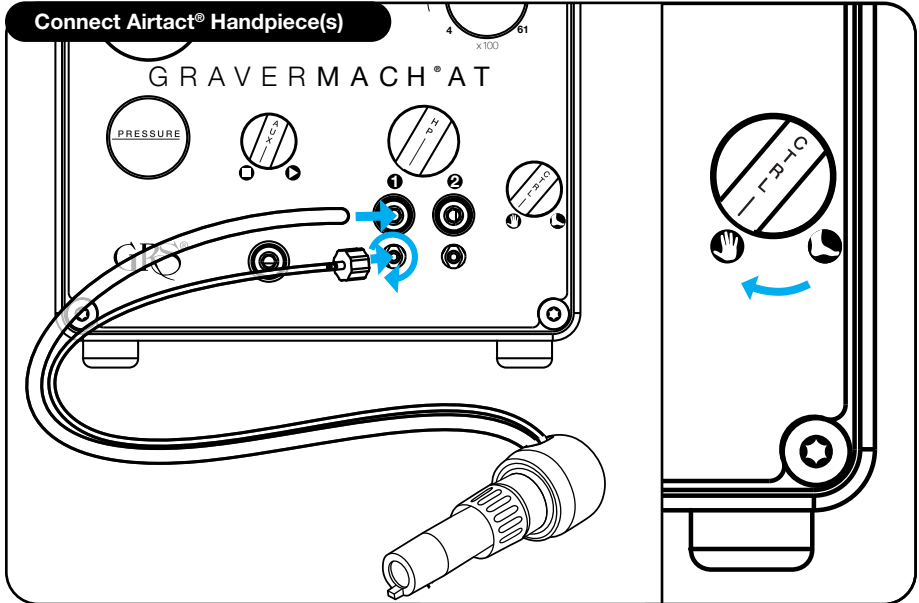

Handpiece Operation

Press the handpiece knob to actuate the Airtact handpiece.

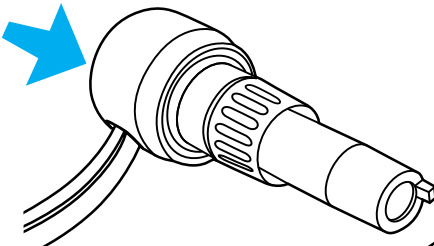

Maintenance & Repair

Contact us for issues or problems you may have with your handpiece.

Email: hello@grs.com

Call: 800-835-3519
8:00am-5:00pm CST

HANDPIECE TUNING

Turn the Speed Dial to 2300.

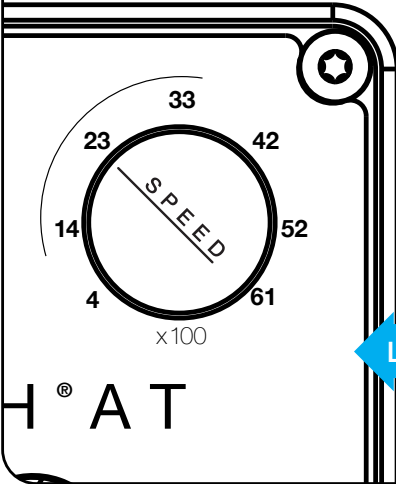

SPEED

Stroke speed is a matter of personal preference and experience. Experiment with the settings to better understand how the speed relates to technique. Each handpiece has a normal speed range. Operating outside this range can produce erratic results.

Strokes Per Minute

LOW

HIGH

STIPPLING
AND SIMILAR
TECHNIQUES

MAXIMUM-POWER
TASKS

FINE CUTS
AND
FINISHES

Set the Air Pressure to 5 psi
(0.4 bar).

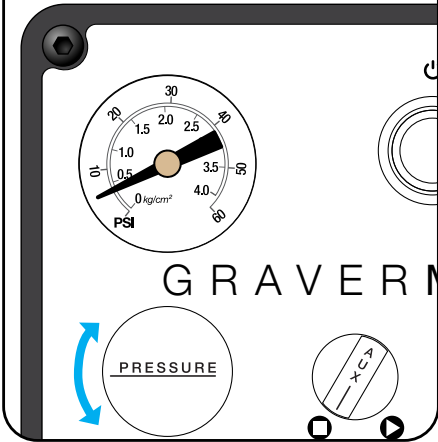

Hold the selected
handpiece vertically near
either ear as shown.

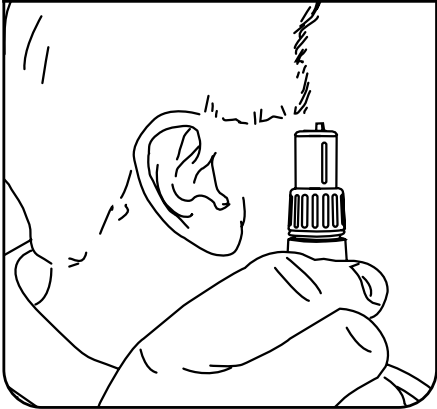

HANDPIECE TUNING (CONTINUED)

WITHOUT operating the pedal, slowly increase the air pressure.

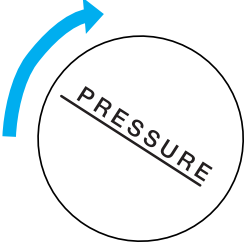
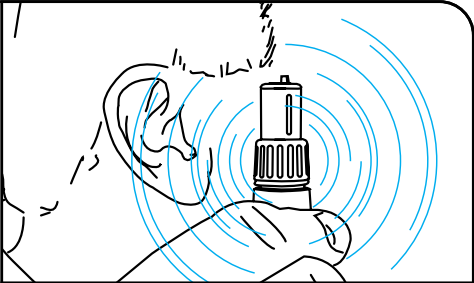
Once the pressure increases enough, the handpiece will begin to knock.

Stop adding air pressure immediately after the knocking stops.

This is the perfect air pressure operating range for the selected handpiece model.

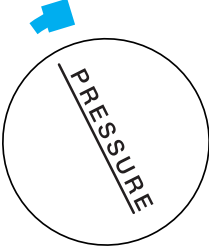
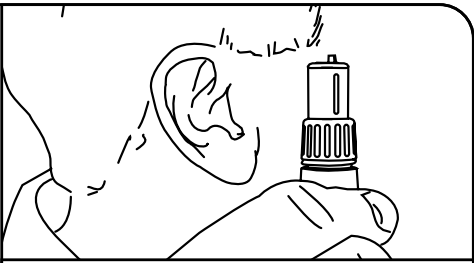
The settings in the chart may be used for adjusting the selected handpiece; this method is not as precise. Set the SPM dial and the air pressure control knob to the Recommended Initial Setting for the selected handpiece.

HANDPIECE FINE ADJUSTMENT

HANDPIECE	TYPE	SPEED <i>Operating Range</i> Recommended	PRESSURE <i>Operating Range</i> Recommended
Monarch™ 004-921, 004-926, 005-921-AT	Standard	2000-5000 3000	10-13 psi (0.7-0.9 bar) 11 psi (0.8 bar)
	Fine	2000-5000 3000	6-8 psi (0.4-0.6 bar) 7 psi (0.5 bar)

MONARCH® AT HANDPIECE

PARTS LIST #005-921-AT

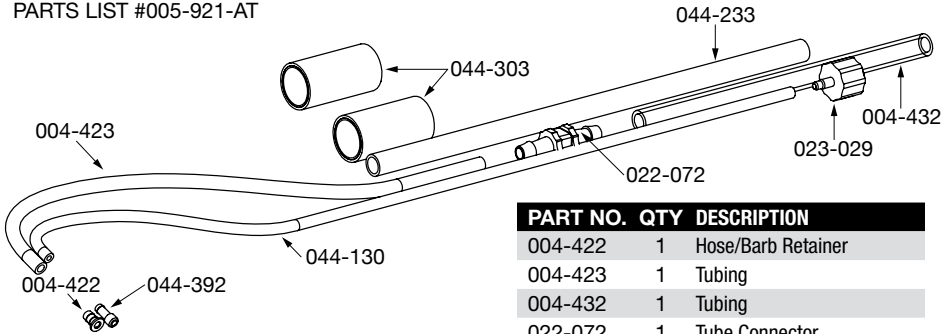

PART NO.	QTY	DESCRIPTION
004-422	1	Hose/Barb Retainer
004-423	1	Tubing
004-432	1	Tubing
022-072	1	Tube Connector
023-029	1	Fitting
044-130	1	Tubing
044-233	1	Braided Sleeve
044-303	2	Heat Shrink Wrap
044-392	1	Air Inlet

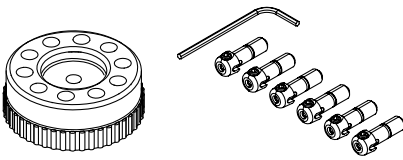

PART NO.	QTY	DESCRIPTION
002-605	1	Wrench
004-326	1	QC Storage Tray
004-803	6	QC Tool Holder

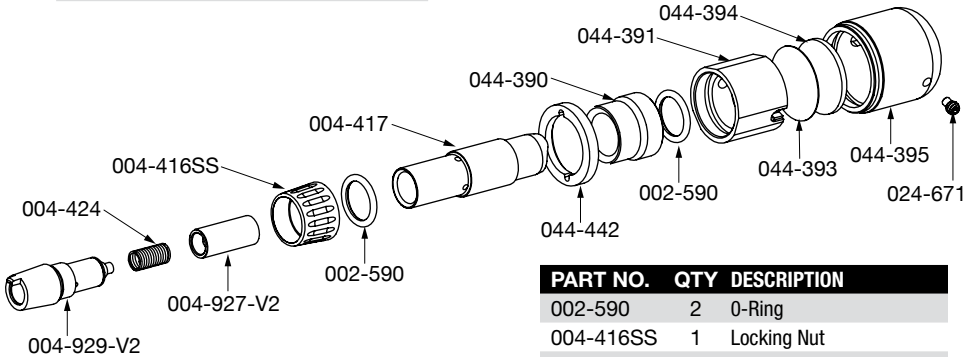

PART NO.	QTY	DESCRIPTION
002-590	2	O-Ring
004-416SS	1	Locking Nut
004-417	1	Handpiece
004-424	1	Spring, Monarch Standard
004-927-V2	1	Piston
004-929-V2	1	Receiver
024-671	1	Set Screw
024-672	1	Set Screw
044-390	1	Nose Piece
044-391	1	Rear Section
044-393	1	Disk
044-394	1	Pressure Disk
044-395	1	Shell Knob
044-442	1	Monarch Lock Collar

GLENDO LLC

900 Overlander Road • Emporia, KS 66801 USA
 800-835-3519 • 620-343-1084 • Fax: 620-343-9640
 hello@grs.com • grs.com
 Last Update: 01/08/2025