



Standard Block Ball Vise For Engraving and Jewelry Making

INSTRUCTIONS • #003-530

Your GRS Standard Block will provide many years of trouble-free service. It is extremely rugged in construction, yet is relatively simple and easy to maintain. Lubrication required is minimal.

The jaw adapter plates are drilled to accept engraving block attachments. GRS offers the 520 Attachment Set (#003-520) that includes storage for the adapter plates and pins that come with the block.

Maintenance

Based on usage, open jaws fully and clean any dirt and metal pieces from the threads. After cleaning, apply a small amount of light oil to the threads.

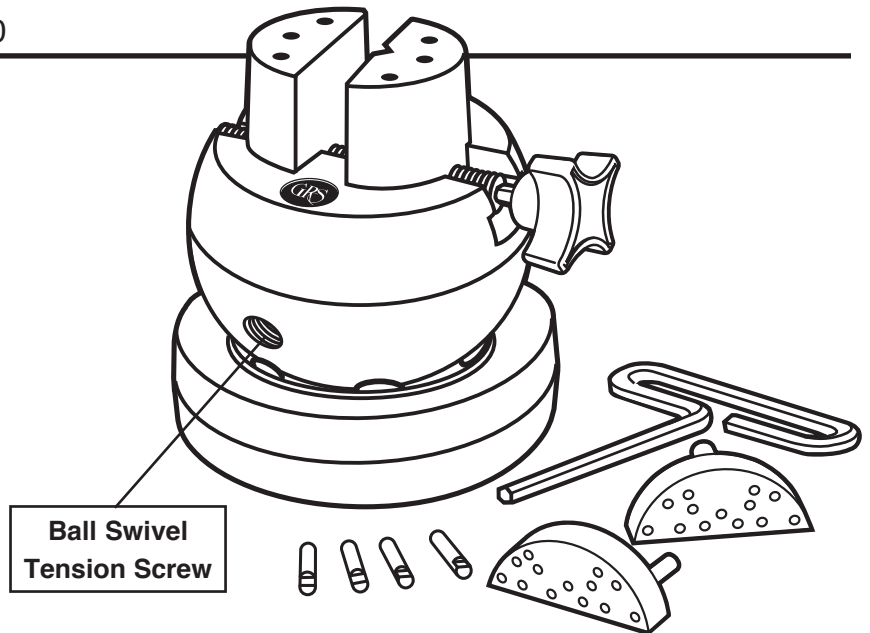

Vise Jaw Thread Replacement • #003-627 & #003-628

Overtightening the jaws will cause wear and damage to the threads. If jaws become loose, replace with kit #003-627. Remove the jaws by opening them as wide as possible until they come off the end of the jaw screw (FIG. 1). The jaw thread pin is located on the underside of each jaw. NOTE: Before removing pins, locate the one with the "L". This is the left hand thread pin and will need to be replaced with the same. Apply a small amount of synthetic grease (included in kit) to the O-rings and jaw screw before installing them. Lift the jaw screw out of the yoke and replace it. Note which side the left hand thread is on. Grease the threads and yoke well.

Start the jaw threads at the same time when replacing them (FIG. 2). Hold each jaw in position and turn the jaw screw to close them. Either a large rubber band or a second person is useful to hold the jaws against the thread while the jaw screw is turned. If the jaws don't meet at the same time in the center, remove them and try starting the threads at the same time again.

Rotational Lock Replacement

The LOCK or DRAG PIN is subject to wear and may need replacement after extended use. Simply remove the ball swivel tension screw with the hex wrench. The Spring and Lock Pin should follow (FIG. 3). If not, turn the ball until they fall out. Replace the Lock Pin (#003-046), Spring, and Tension Screw.

Turntable Base For Microscope Work • #003-616-V2

To use the Turntable Base, lock the vise by tightening the swivel tension screw until the ball will not turn. The turntable now becomes the means of rotation, allowing the work to be centered in the field of view of the microscope. Align the center of the turntable with the center of the microscope view (FIG. 4). Change working views by repositioning the vise.

Thread Pin Replacement Kit • #003-628

Includes Jaw Screw, Left and Right Thread Pins, O-Rings, and Tube of Synthetic Grease.

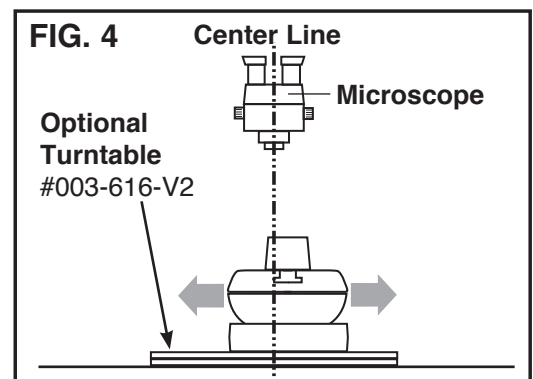
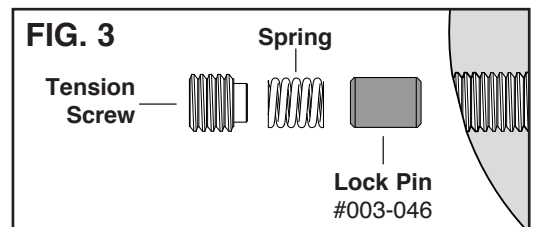
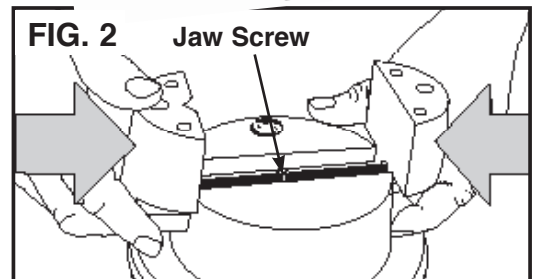
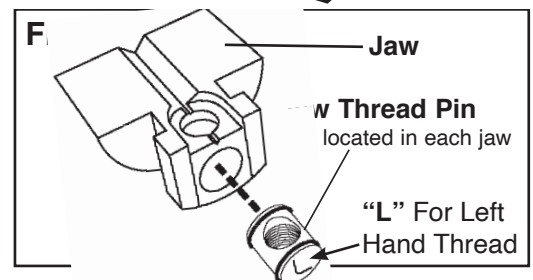



Standard Block Ball Vise For Engraving and Jewelry Making

PARTS LIST • #003-530

GRS Standard Block Ball Vise Complete Assembly #003-530

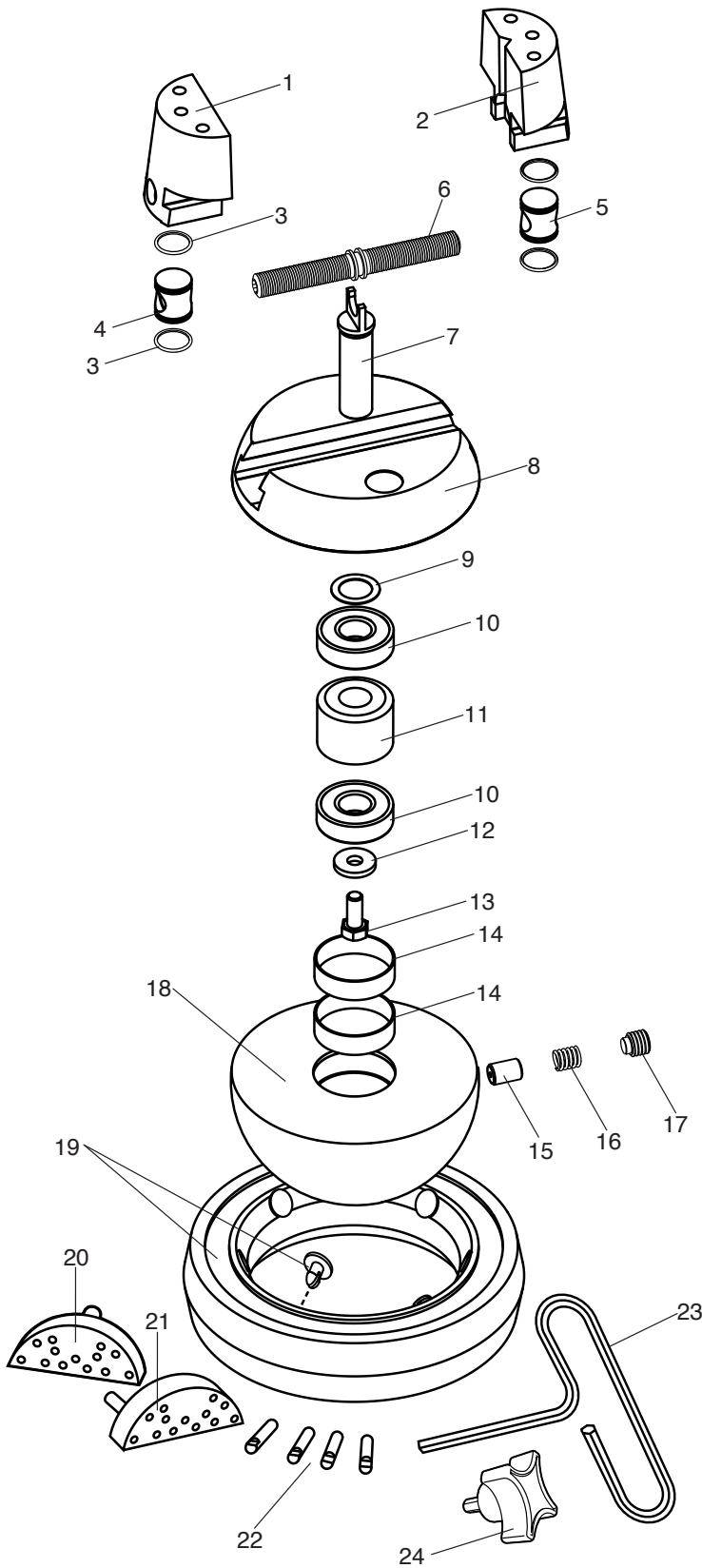

PART #	DESCRIPTION
1	003-073 Jaw - Right Hand
2	003-074 Jaw - Left Hand
3	002-127 O-Ring - 0.625" x 0.75" x 0.062"
4	003-065 Pin - Right Hand
5	003-064 Pin - Left Hand
6	003-070 Screw Post
7	003-213 Post
8	003-210 Block Crown S.S.
9	022-180 Washer
10	022-181 Bearing 6203ZZ
11	003-214 Spacer
12	002-214 Washer - 0.312" x 0.859" x 0.125"
13	003-265 5/16-18 x 3/4" Flange Head
14	022-182 Tolerance Ring
15	003-211 Lock Pin
16	003-212 Spring
17	003-067 1/2 - 13 x 1/2 SSS Flt Pt HF Dog
18	003-215 Block Base S.S.
19	003-529 Tire Assembly
20	003-526 Pin Plate - 1 pin
21	003-527 Pin Plate - 2 pin
22	003-015 Jaw Pin - 1/4"
23	002-091 Wrench - 1/4" T-Handle Hex
24	003-661 1/4" Hex Drive Knob

GLENDO LLC

900 Overlander Road • Emporia, KS 66801 USA
800-835-3519 • 620-343-1084 • Fax: 620-343-9640
grs@grstools.com • grs.com
Last Updated: 2020-06-02