

TURNTABLE MOUNT KIT INSTRUCTIONS

Part #004-672

Tools required to mount the Turntable Base on a Large Block Shelf: Center Punch, Hammer, Electric Drill -or- Drill Press, 7/32" -or- 1/4" metal drill bit, phillips screw driver, scissors and tape.

Cut out the template below and position it on the Large Block Shelf as shown in (ILL. A). Tape the template to the table surface when you have the left and front tabs flush with the edge. Center punch each of the four holes to be drilled. Remove the template and drill 7/32" to 1/4" (.219" to .250") holes.

Attach the turntable by placing the spacers between the shelf and turntable, inserting the bolts with washers through them and tightening into the tapped holes located in turntable bottom. Do not overtighten. (See ILL. B)

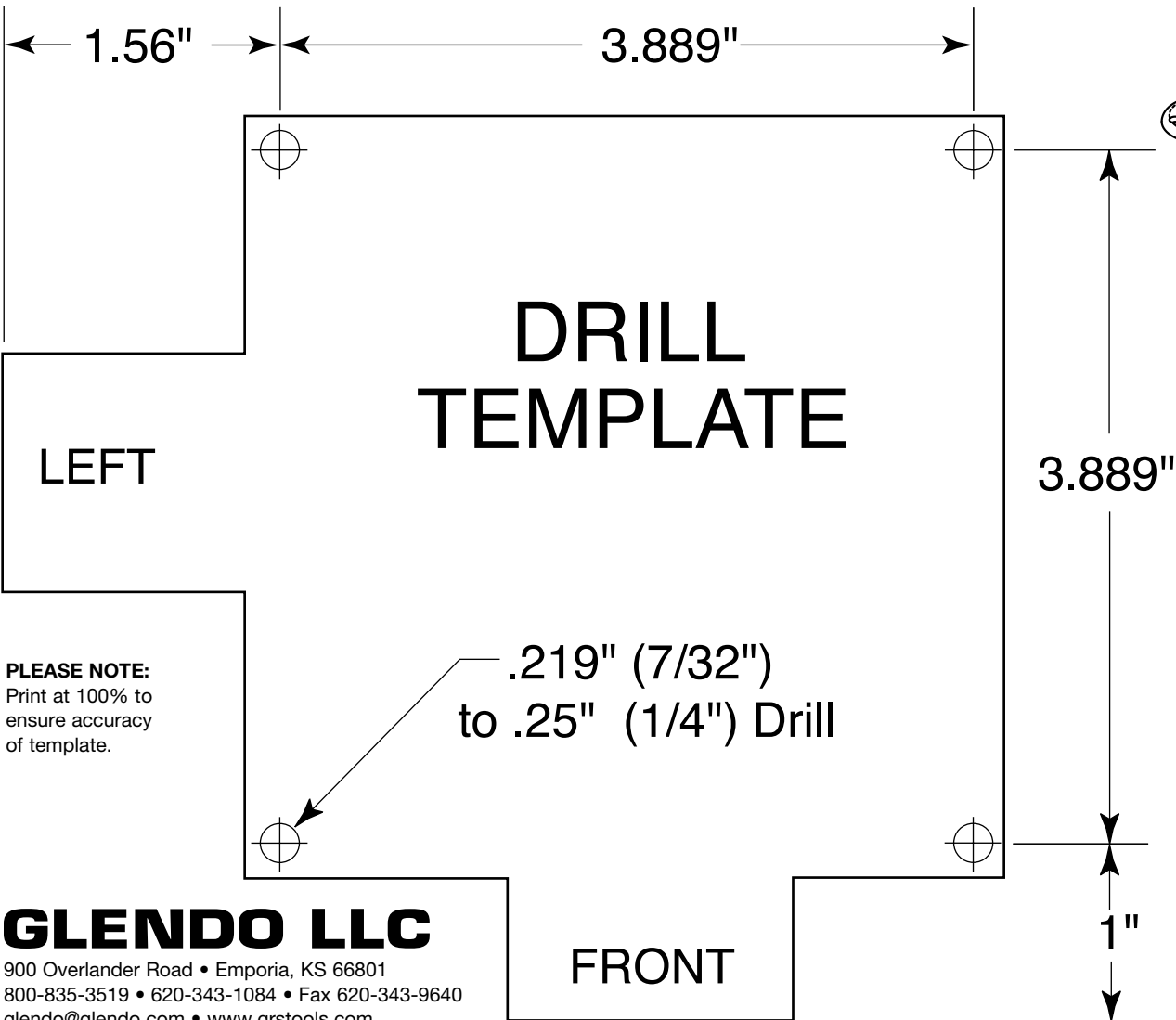
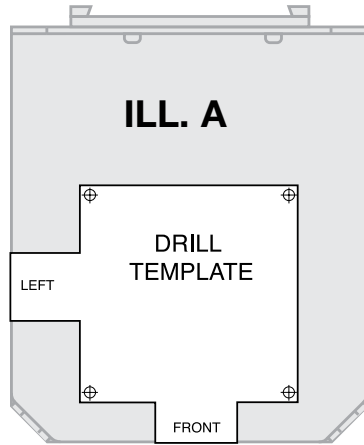

PLEASE NOTE:
Print at 100% to ensure accuracy of template.

GLENDO LLC

900 Overlander Road • Emporia, KS 66801
800-835-3519 • 620-343-1084 • Fax 620-343-9640
glendo@glendo.com • www.grstools.com
Last Updated: 2014-12-17 LIT-229

Turntable Base
#003-616-V2

Large Block Shelf
#004-665

NOTE: YOU CAN NOT MOUNT A TURNTABLE ON THE STANDARD BLOCK SHELF #004-578

SPACER
(QTY. 4) #003-201

TEMPLATE
(SEE BELOW)

WASHER
(QTY. 4) #002-247

MACHINE SCREW
(QTY. 4) #002-102

BLOCK VISE SHELF SUPPORT
#003-649

