

# JURA

BY GRS®



## QC ADVANCED SET

INCLUDING VISE

# 500-517 • INSTRUCTIONS

Includes: MicroBlock® w/ Jura Master Jaws, Small Vise Base, Jura Must Have 5 mm Hex Key, Organizers, Horizontal Inside Ring Holder, Vertical Inside Ring Holder, 10 Plastic Collets, Flat Clamps with Groove, Outside Ring Holder, 6 mm Cylinder Top, 10 mm Cylinder Top, 20 mm Round Top, 20 mm Straight Top, 40 mm Straight Top, Engravers Clamps with 2.34 mm Holes, Thermo-Loc® Engravers Clamps, Shellac Plate, Thermo-Loc Cylinder, Shellac Cylinder, Tapered Point Holders, Tapered Ball Holders, Drill Head Holder, 10 Hand Chucks, Digital Divider, Ceramic Scribe, Tweezers, Carbide Pick

# MASTER JAWS

## INSTRUCTIONS

Instructions apply to the following product(s):



500-018

### IMPORTANT NOTE:

The MicroBlock® and MicroBlock® XL Jura by GRS sets include a pair of Master Jaws instead of the original jaws with pin holes.

Skip to **Installation of Master Jaws** unless you need to remove original MicroBlock jaws from a previously purchased vise.

**Products that include Master Jaws instead of original MicroBlock jaws:**

#500-508, #500-510, #500-517,  
#500-526, #500-527

✓ Included with this set.

◆ Not included with this set. Available separately.

### Removal of Original MicroBlock® Jaws

Skip to **Installation of Master Jaws** unless you need to remove original MicroBlock jaws from a previously purchased vise.



### Installation of Master Jaws

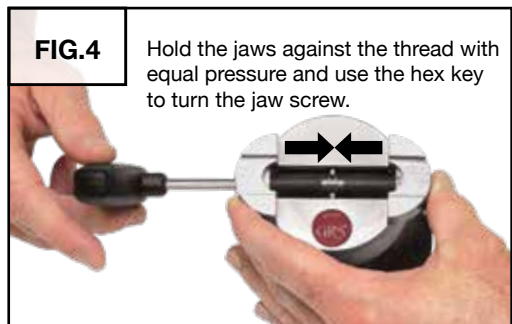

Microblock® shown with Jura Master Jaws #500-018  
 (See instructions for installation on pg 2).

# MICROBLOCK® W/ MASTER JAWS

## INSTRUCTIONS AND PARTS LIST

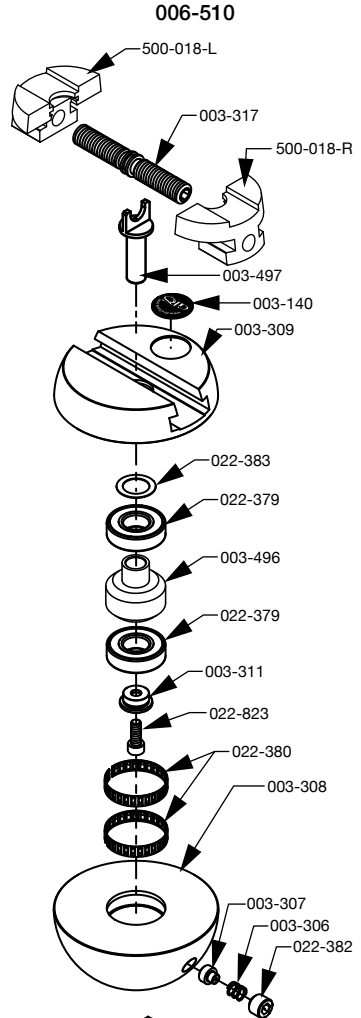
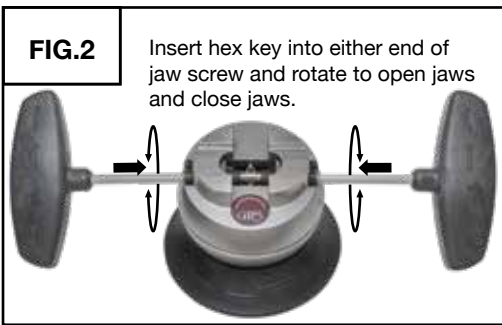
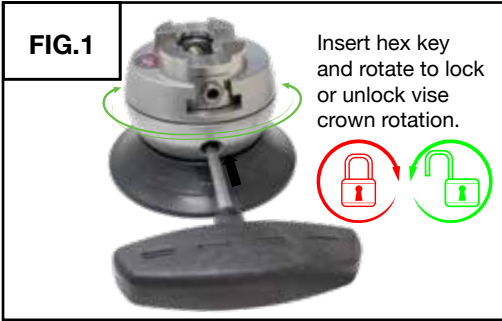

PART #	DESCRIPTION	QTY
002-067	10-32 x 1/2" SHCS	1
003-140	GRS Label	1
003-306	Drag Spring	1
003-307	Lock Pin	1
003-308	Stainless Steel 80 mm Base	1
003-309	Crown	1
003-311	Bearing Retainer	1
003-496	Bearing Spacer Brake Rotor	1
003-497	Jaw Screw Yoke	1
003-317	Jaw Screw	1
003-679	Thermo-Loc Sample Kit	1
022-379	Shielded Bearing	2
022-380	Tolerance Ring	2
022-382	Flat Nose Set Screw	1
022-383	.015" x .513" x .750" SS Washer	1

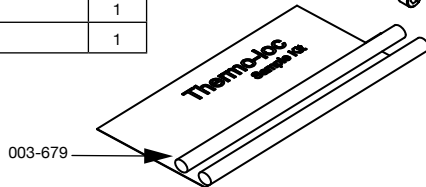

# SEATED QC FIXTURES

## INSTRUCTIONS

Instructions apply to the following product(s):

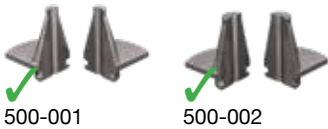

✓ Included with this set.  
◆ Not included with this set. Available separately.

### Fixture Attachment



BOTTOM



SIDE



ANGLE

### Master Jaw Seat



### Fixture Installation



# INSIDE RING HOLDER SCREW SET

## INSTRUCTIONS

Instructions apply to the following product(s):



500-011

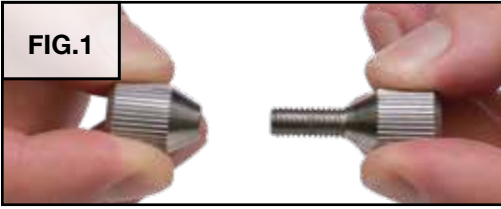

# SHELLAC CYLINDER

## INSTRUCTIONS

Instructions apply to the following product(s):



✓  
502-015



Follow the shellac instructions to apply shellac and workpiece to cylinder.

# THERMO-LOC® CYLINDER

## INSTRUCTIONS

Instructions apply to the following product(s):



✓  
502-502

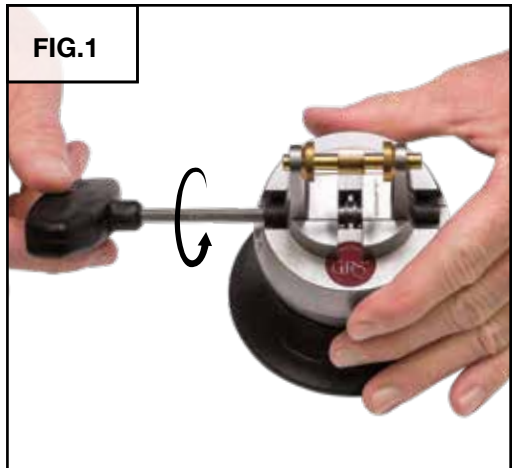

Follow the Thermo-Loc® instructions to apply Thermo-Loc® and workpiece to cylinder.

✓ Included with this set.

◆ Not included with this set. Available separately.

## Fixture Installation

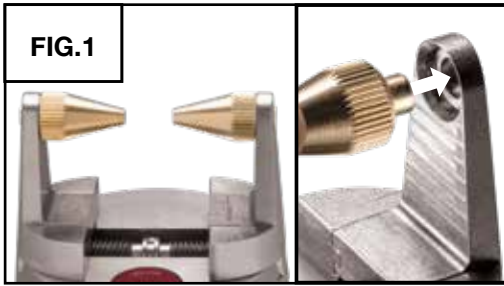

# POINTED AND TAPERED BALL HOLDERS

## INSTRUCTIONS

Instructions apply to the following products:



## Fixture Usage

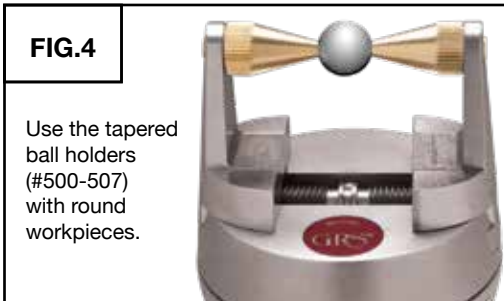
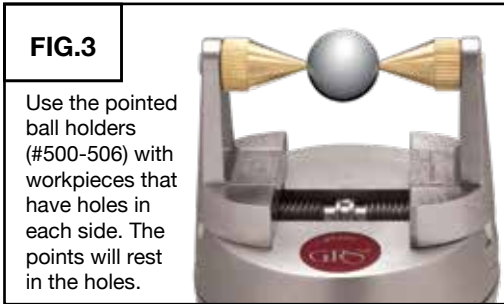
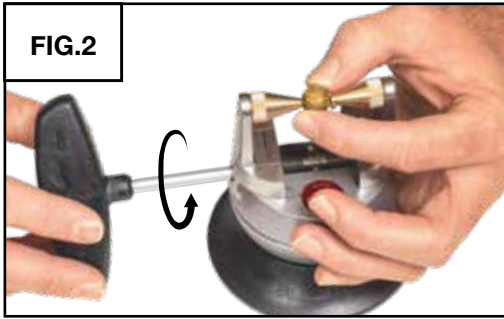

# ROUND-BASE QC FIXTURES

## INSTRUCTIONS

Instructions apply to the following product(s):



500-501



502-501

### Fixture Attachment



BOTTOM



SIDE



ANGLE

### Fixture Installation

FIG.1



FIG.2



FIG.3

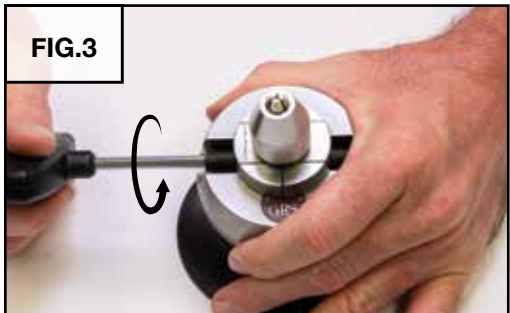

✓ Included with this set.

◆ Not included with this set. Available separately.



# VERTICAL RING HOLDER

## INSTRUCTIONS

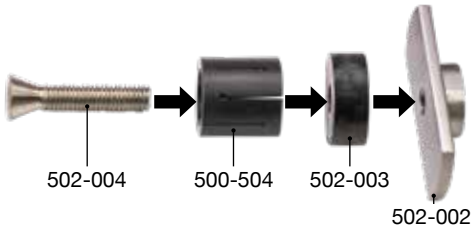

Instructions apply to the following product(s):

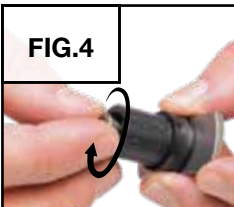
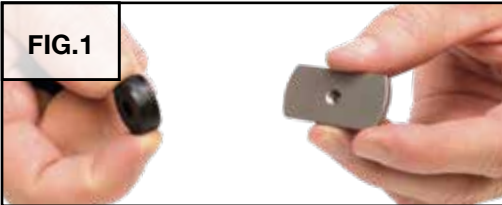

# QC SHELLAC PLATE

## INSTRUCTIONS

Instructions apply to the following product(s):



500-014

### Fixture Attachment

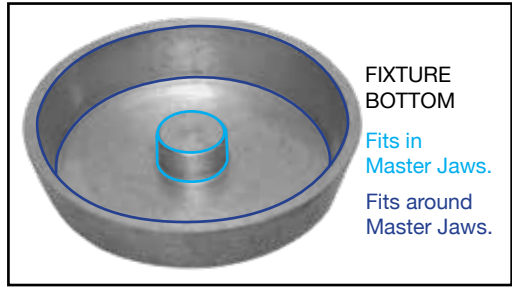

### Fixture Installation



✓ Included with this set.

◆ Not included with this set. Available separately.

Follow the shellac instructions to apply shellac and workpiece to plate.

## Overview

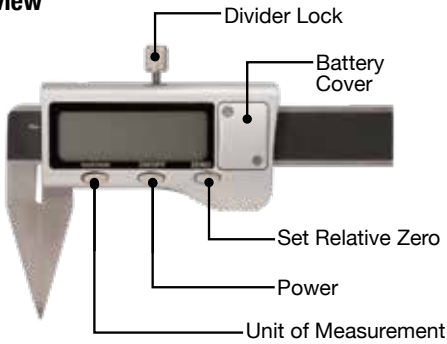

# DIGITAL DIVIDER

## INSTRUCTIONS

Instructions apply to the following product(s):



## Battery Installation

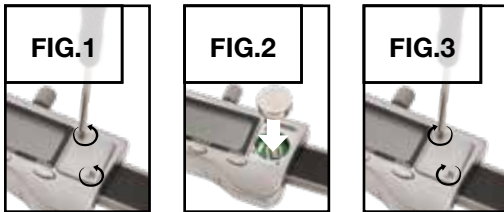

## Divider Sharpening

Divider must be sharpened to use for marking metal. Use rotary handpiece diamond wheels (#023-123 and #023-120) to sharpen. With divider jaws closed, grind away excess metal to form point.

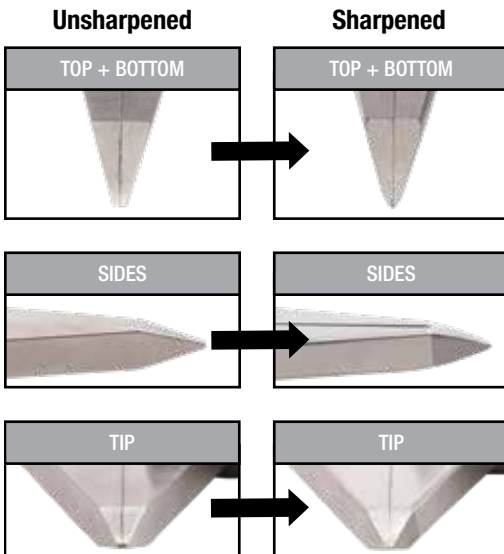

# ORGANIZERS WITH TAPE ATTACHMENT

## INSTRUCTIONS

Instructions apply to the following product(s):



500-523



500-524



502-034



502-045



523-011



523-012



523-013



523-029



523-030



FIG.1

Clean organizer back and bench surface with isopropyl alcohol according to manufacturer's instructions.



FIG.2



FIG.3



FIG.4



FIG.5



FIG.6

Place organizer where desired and press firmly for 60 seconds.

✓ Included with this set.

◆ Not included with this set. Available separately.

**FIG.1**

Hold the organizer where you would like it to be attached and mark where the screw holes will be.



**FIG.2**

Drill  $7/64$ " diameter pilot holes,  $5/8$ " deep in the spots you marked.



**FIG.3**

Place the screws in the holes.

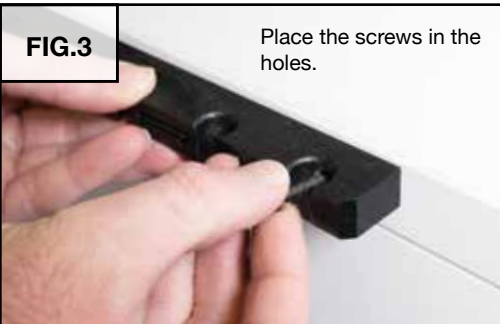

**FIG.4**

Tighten the screws with a drill or screwdriver.

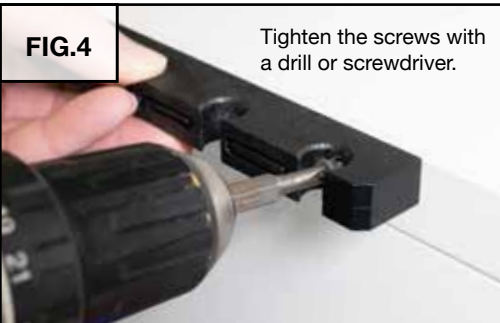

# ORGANIZERS WITH SCREW ATTACHMENT

## INSTRUCTIONS

Instructions apply to the following product(s):



523-014

# NOTES

# NOTES

