

# GRS<sup>®</sup> Turntable Brake Kit INSTRUCTIONS & PARTS LIST

for GRS<sup>®</sup> Turntable Base V2 • PART #003-343

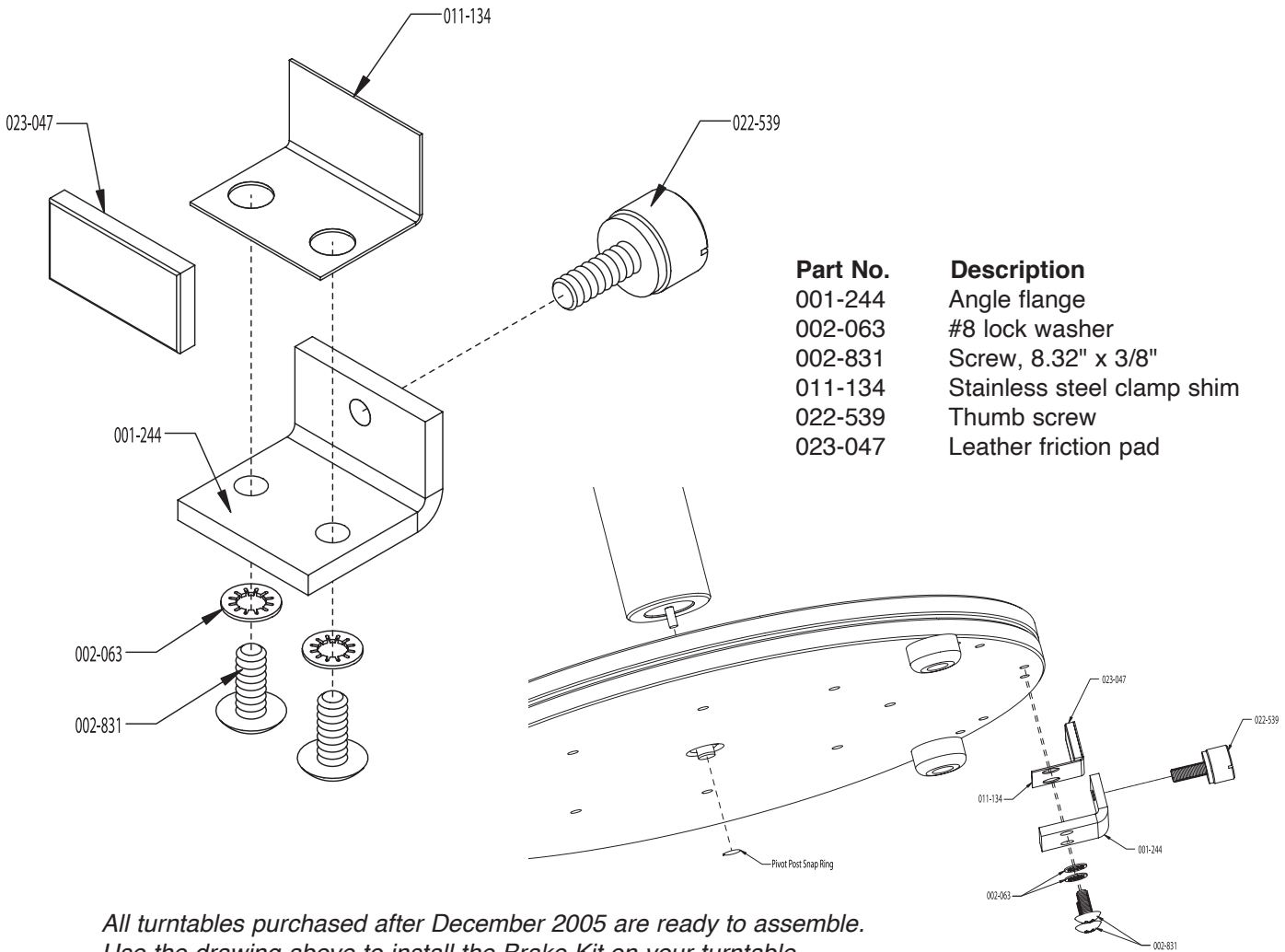

Part No.	Description
001-244	Angle flange
002-063	#8 lock washer
002-831	Screw, 8.32" x 3/8"
011-134	Stainless steel clamp shim
022-539	Thumb screw
023-047	Leather friction pad

All turntables purchased after December 2005 are ready to assemble. Use the drawing above to install the Brake Kit on your turntable.

## INSTALLATION INSTRUCTIONS

If your turntable was purchased prior to December 2005, you will have to drill and tap the 2 holes needed to mount this Brake Kit to your turntable. A: Cut out and use the template on page 2 to layout the 2 locations by carefully placing the template on the bottom of the turntable plate. B: Use a scribe to mark the center of each hole. Remove the paper and drill each hole with a .136" drill (#29 drill or 3.5mm) and cut the threads using a #8-32 tap. Assemble the Brake Kit according to the drawings.

**HINT:** The turntable can be disassembled to facilitate an easier job of drilling and tapping these 2 holes. Using a large towel spread out on a bench or table, lay the turntable face down and place a piece of tape across the small pivot post snap ring to prevent it from flying off when loosening the bottom plate from the top. With 2 screwdrivers positioned 180 degrees apart, gently leverage the 2 sides of the bottom plate up until the snap ring pops off the pivot post. Remove the bottom plate and drill according to the instructions above and re-assemble.

## GLENDO LLC

900 Overlander Road  
P.O. Box 1153  
Emporia, KS 66801 USA  
800-835-3519 • 620-343-1084  
fax 620-343-9640  
glendo@glendo.com  
www.grstools.com

Template for turntables  
manufactured before  
January 2006.

