

PACKAGE CONTENTS

The Silentair compressor comes in two boxes.

Box #1 (Small Box) Contains:

- Compressor Fan – (#004-693)
- 1 Bottle of Silentair Synthetic Oil, with Applicator Spout – (#022-163)
- Silentair Reservoir Bottle

Box #2 (Large Box) Contains:

- Silentair Compressor Assembly, with Coalescing Filter
- Silentair Regulator / Primary Filter
- 2 Rolls of Nylon Tubing
- Packet of Threaded Fastener*, Short Clear Hose*, and Black Air Intake Filter
(Attached to Red Cap on Compressor)

**Not used for this application.*

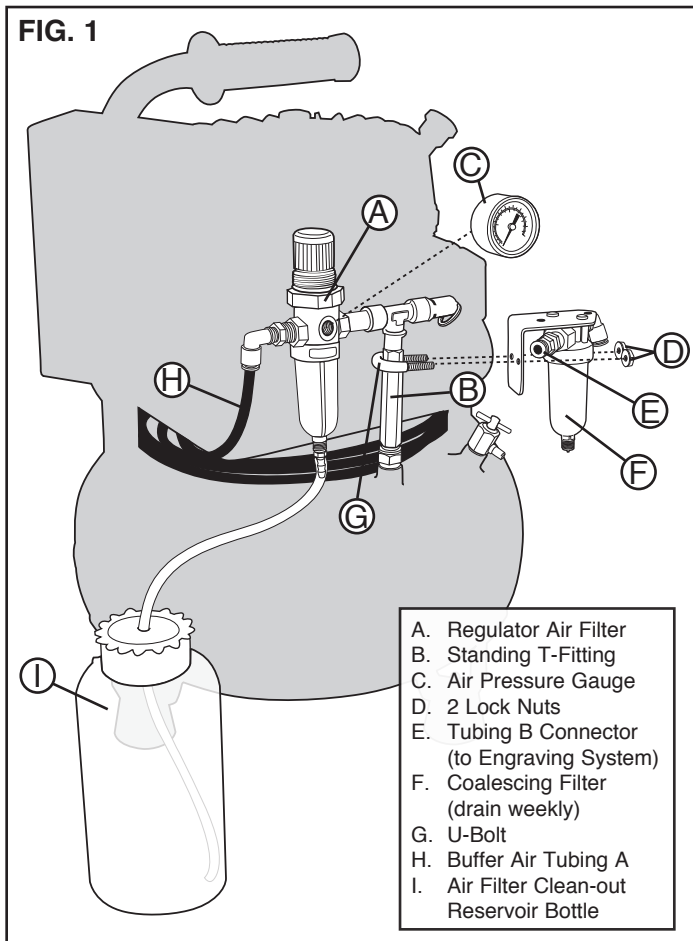

NOTE: The air filter will empty contents of bowl into the Reservoir Bottle. The bottle will need to be checked and emptied often to avoid overfilling.

NOTE: Before using this compressor, read all instructions to avoid damaging the equipment.

INSTALLATION

1. Begin by installing the Coalescing Filter (Fig. 1.E). Remove the 2 Lock Nuts (Fig. 2.D) that hold the U-bolt (Fig. 2.G) on the bracket.
2. Wrap the U-bolt (Fig. 3.G) around the Standing T-Fitting (Fig. 3.B) that rises out of the air tank. Slide the Coalescing Filter bracket onto the threads. Use your fingers to thread the nuts evenly, then use a 7/16" wrench to tighten. NOTE: For the most secure fit, place back of bracket against a flat side of the Standing T-Fitting.
3. Install the Silentair Regulator Air Filter (Fig. 4) by threading it onto the pipe nut located on the T-Fitting. Do not over tighten!
4. Install the Air Pressure Gauge (Fig. 5.C) by simply threading the gauge into the fitting below the Air Filter (Fig. 5.A) as shown.
5. Install the Silentair Reservoir Bottle (Fig. 6.I) by pushing the bowl drain hose into the hole in the cap of the bottle. NOTE: Located on the side of the compressor top cover is a red protector cap covering the air intake opening, red warning label and zip-lock bag. Unthread the red protector cap and remove the tag and bag.

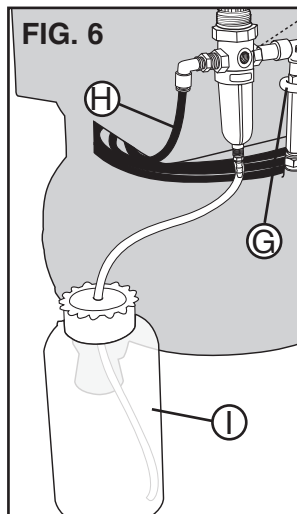
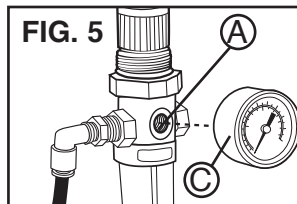
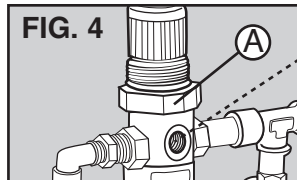
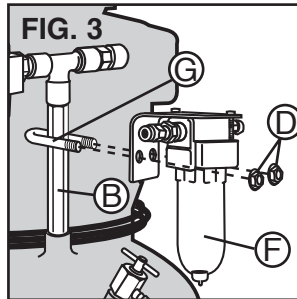
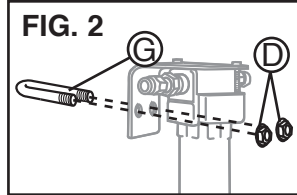

- Open the bottle of Silentair Synthetic Oil. Using the Applicator Spout, carefully add the oil through the Air Intake opening. As an alternative, you can add the oil through the plug at the top of the head marked OIL by unthreading the knob.

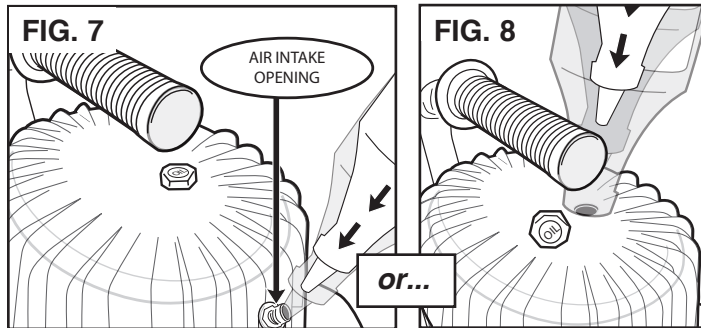

- Check the oil level on the sight glass located by the T-Fitting. The oil should be at the halfway mark.

NOTE: For best operation, change and refill the oil with fresh Silentair Synthetic Oil after the first 150 hours of compressor use. **USING ANY OTHER OIL VOIDS THE 1-YEAR MANUFACTURER'S WARRANTY** and will cause increased wear and excessive oil blow-by.

- Install the Air Intake Filter by threading it into the Air Intake opening.

- Two sets of tubing are included:

Buffer Air Tubing A (FIG. 1.H)

- Extra length replacement tubing for around the compressor pump head.
- Allows air from the compressor to cool, depositing oil droplets in the tubing before going to the Coalescing Filter.
- Replace when Coalescing Filter is replaced, or if tubing becomes contaminated with oil.

Tubing B (Connects to FIG. 1.E)

- 50 ft. (30.5 m) long.
- **Use entire length. Coil excess.**
- Connects compressor to engraving system.

- To connect Tubing B:

- Connect the end **without** a compression fitting to Tube B Connector (FIG. A-5).
- Gently snug the nut using a wrench.
- Connect the other end to engraving system.

NOTE: To connect a GraverMax SC or GraverMach, remove the tube fitting. Install the tube directly into the Quick Disconnect.

- Follow the Installation Instructions on the following page to install the Auxiliary Cooling Fan.

ADDITIONAL INSTRUCTIONS, NOTES & MAINTENANCE HINTS

• **OPTIMAL OPERATING PSI** • This compressor has been adjusted to provide a maximum of 80 psi (plus or minus 10 psi). By operating at this conservative 80 psi pressure, the compressor stays cooler. The air pressure is ample for operating air tools such as a GraverMach, GraverMax SC, System 3, rotary handpieces, and other similar air tools.

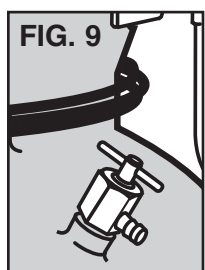

• **DRAINING WATER** • Water is generated as a by-product of compressing air. The small T-Fitting with the spout is for draining the air tank. (FIG. 9) The valve has an extension that goes to the tank bottom to allow complete system draining. It is not necessary to

remove the bottom tank plug or tip the compressor on its side to drain water. Drain regularly as needed.

• **SHIPPING** • If shipping is required, remove ALL OIL to prevent oil leakage and damaging oil contamination of the air components. Do not assume the shipper will keep the box upright during transit.

• **USING THE RIGHT OIL** • This air compressor is designed to be remarkably quiet and long-lasting. To accomplish this, it requires special oil inside the compressor housing. The right oil to use – Silentair Synthetic Oil (#022-163) – is included with the compressor. Call GRS to order additional bottles.

• **CHANGING OIL** • When changing the compressor oil, warm a cold machine up by running it for several minutes and then unplug the electric cord. Drain the tank of water and coalescing filter bowl of oil/water. Remove the Air Intake Filter located in the compressor head. Tip the compressor over on its side to drain the used oil from the pump housing into a suitable container. Properly dispose of used oil. Stand machine back up on a level surface and refill to the correct level with fresh Silentair Oil.

For help with this product or to order additional supplies, please call GRS at 1-800-835-3519 or 620-343-1084 (Monday – Friday, 8 am – 5 pm).

Always add oil before use.

GRS[®] Auxiliary Cooling Fan

INSTRUCTIONS • #004-693 / #004-693-230

This Compressor Fan should be used to correctly prevent overheating that may affect normal operation.

INSTALLATION

1. Mount the fan on the handle post of your compressor. (FIG. 10.B, FIG. 11.A).
2. Use the U-bolts to secure the fan to the handle post.

NOTE: The white nylon washers are used as spacers as needed for smaller diameter posts to tighten the fan in place.

3. Plug the cord into an A.C. outlet and test air flow (FIG. 11.B).
4. Make sure the air is directed into the compressor head, not away from it.
5. Use the fan during extended periods of compressor use.

• Turn off the fan when compressor is off.

Auxiliary Cooling Fan comes with a 1-Year Limited Warranty.

VERY IMPORTANT: The fan must be positioned so the direction of the air flow is directly into the compressor head (FIG. 11.B).

FIG. 10
SIDE VIEW

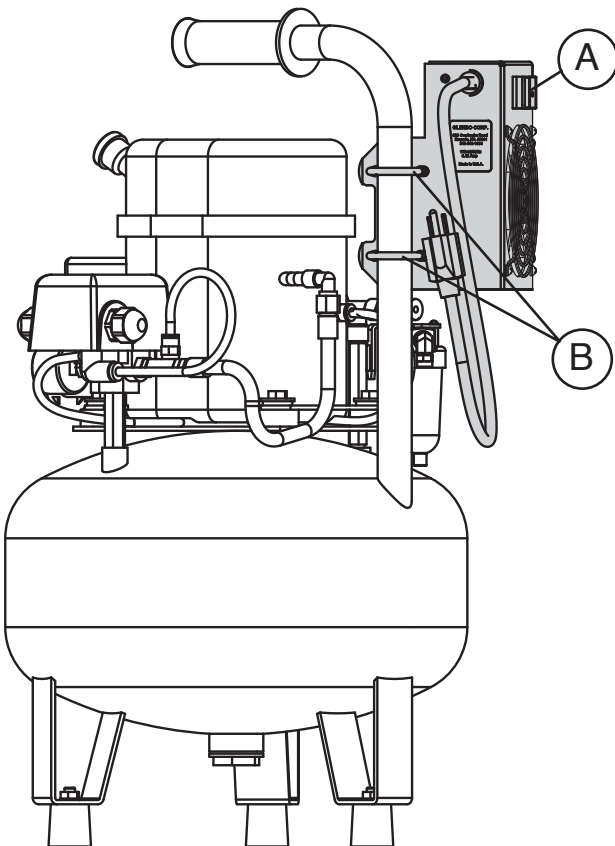
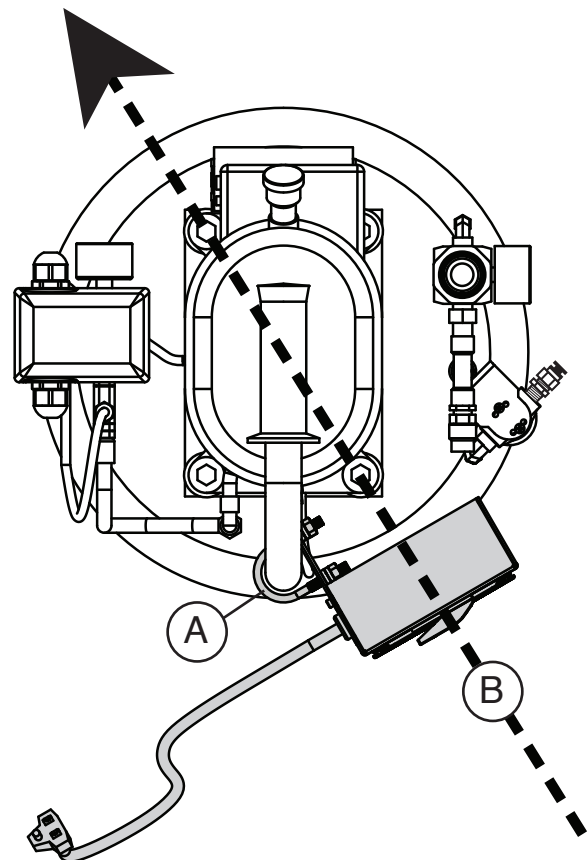
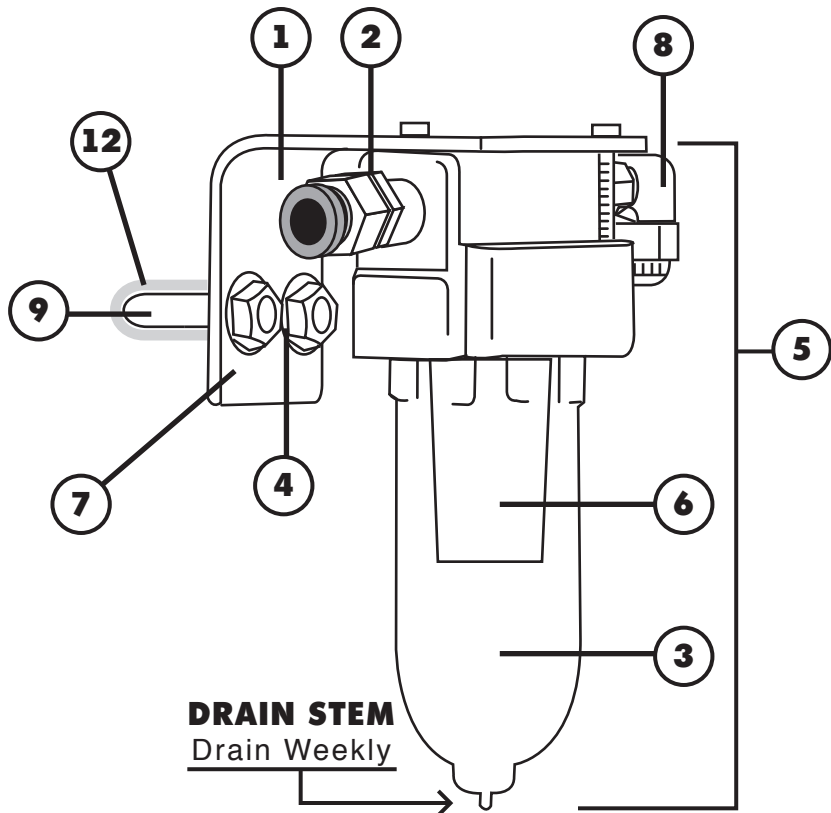

FIG. 11
TOP VIEW



GRS[®] Coalescing Filter with Tubing Connection
 PARTS LIST • #002-618



Item	Part #	Description
1	022-231	Connector
2	002-379	Bushing
3	002-417	Filter Bowl
4	002-536	Nut, 1/4 -20 Lock
5	002-618	Oil Filter, Complete
6	002-633	Filter Element
7	004-402	Mount Bracket
8	022-230	Male Fitting
9	022-129	U-Bolt
*	022-163	Air Compressor Oil
10	050-004	Tubing 15 ft.
11	050-004	Tubing 50 ft.
12	050-008	Tubing

Use entire 50 ft. length of #050-004 Tubing. Coil excess as shown.

