

# GRS<sup>®</sup> MicroBlock<sup>®</sup> XL

INSTRUCTIONS • #003-773

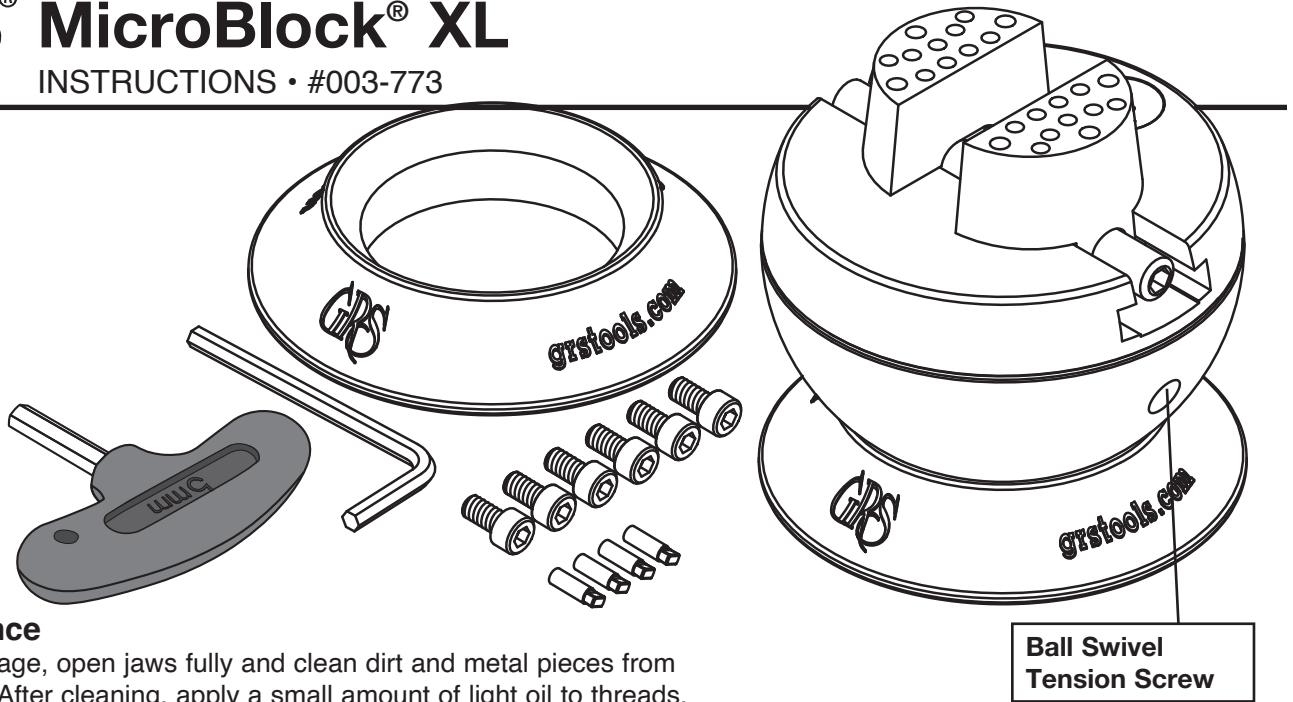

## Maintenance

Based on usage, open jaws fully and clean dirt and metal pieces from the threads. After cleaning, apply a small amount of light oil to threads.

Periodically wipe the vise and vise jaws with a lightweight oil to help prevent rust. All GRS vises are stainless steel except the ONE line vises. Although stainless steel is more rust-resistant, certain body chemistry can still cause it to rust. Recommended products include 3-IN-ONE oil, WD-40 Corrosion Inhibitor, and Super Lube Metal Protector.

## Jaw Thread Replacement

Overtightening the jaws will cause wear and damage to the threads. If jaws become loose, replace with kit #003-829. Remove the jaws by opening them as wide as possible until they come off the end of the jaw screw (**FIG. 1**). The jaw thread pin is located on the underside of each jaw. NOTE: Before removing pins, locate the one with the "L". This is the left hand thread pin and will need to be replaced with the same. Apply a small amount of synthetic grease (included in kit) to the O-ring and jaw screw before installing them. Lift the jaw screw out of the yoke and replace it. Note which side the left hand thread is on. Grease the threads and yoke well.

Start the jaw threads at the same time when replacing them (**FIG. 2**). Hold each jaw in position and turn the jaw screw to close them. Either a large rubber band or a second person is useful to hold the jaws against the thread while the jaw screw is turned. If the jaws don't meet at the same time in the center, remove them and try starting the threads at the same time again.

## Rotational Lock Replacement

The LOCK or DRAG PIN is subject to wear by design and may need replacement after extended use. Simply remove the ball swivel tension screw with hex wrench. The Spring and Lock Pin should follow (**FIG. 3**). If not, turn the ball until they fall out. Replace the Lock Pin (order #003-307), Spring and Tension Screw.

## Thread Pin Replacement Kit #003-829

Includes Jaw Screw, Left and Right Thread Pins, O-Rings, and Tube of Synthetic Grease.

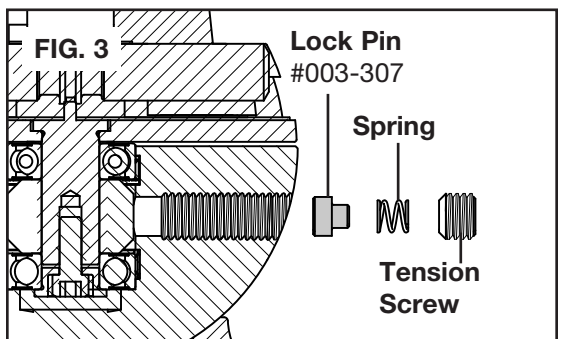
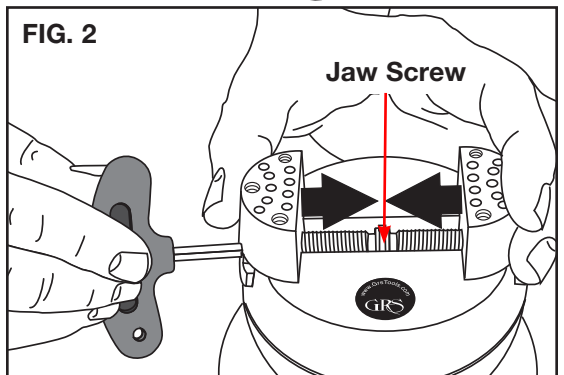
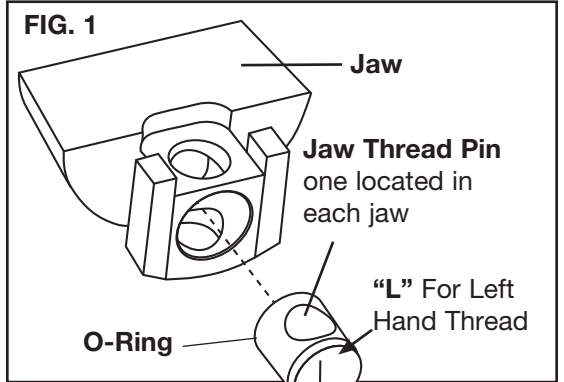

# GRS<sup>®</sup> MicroBlock<sup>®</sup> XL

PARTS LIST • #003-773

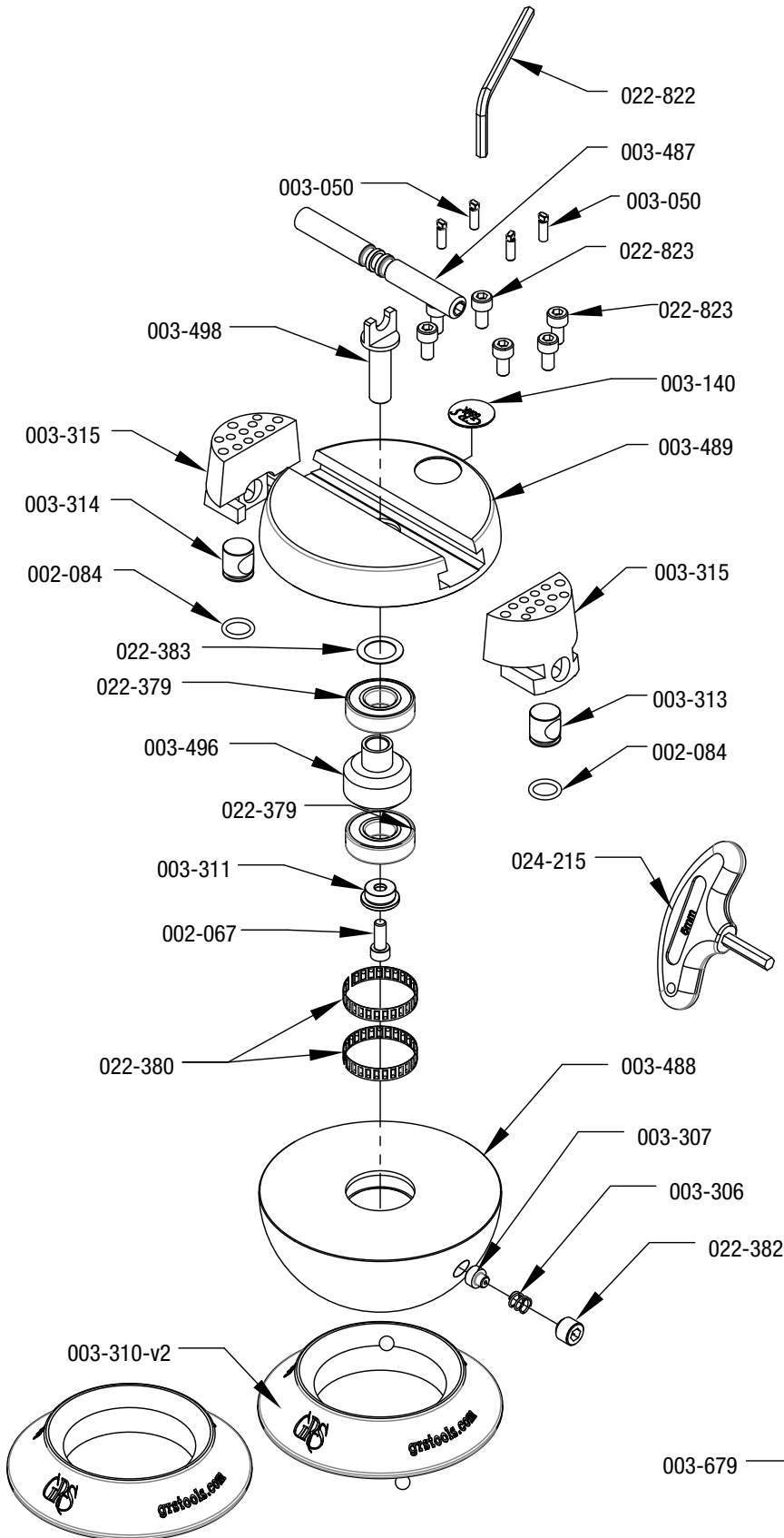

PART #	DESCRIPTION	QTY
002-067	SHCS, #10-32 X .50" BLK	1
002-084	O-RING, 3/8 X 1/2 X 1/16	2
003-050	FORMED COMPLETE ATTACHMENT PIN #1	4
003-140	LABEL, GRS	1
003-306	BRAKE AND DRAG SPRING	1
003-307	BRAKE ELEMENT FOR MICROBLOCK VISE	1
003-310-V2	BLACK MOLDED PLASTIC SUPPORT BASE	2
003-311	BEARING RETAINER FOR MICROBLOCK VISE	1
003-496	BEARING SPACER BRAKE ROTOR MICROBLOCK	1
003-313	RIGHT HAND DRIVE NUT FOR MICROBLOCK	1
003-314	LEFT HAND DRIVE NUT FOR MICROBLOCK	1
003-315	MICROBLOCK VISE JAW	2
003-498	YOKE TO SUPPORT AND CENTER JAW SCREW	1
003-487	JAW SCREW FOR 100MM BLOCK VISE	1
003-488	416 STAINLESS STEEL 100MM BALL BASE FOR MEDIUM VISE	1
003-489	CROWN FOR 100 mm VISE	1
003-679	THERMO-LOC SAMPLE KIT	1
022-379	R8 SHIELDED BEARING	2
022-380	TOLERANCE RING	2
022-382	M10 X 1.5 FLAT NOSE SET SCREW X 8MM	1
022-383	.015 X .513 X .750 SS SHIM WASHER	1
022-822	4MM SHORT ARM HEX WRENCH	1
022-823	M5 X .8 X 10MM LONG SHCS	6
024-215	PURCHASED 5mm X 25mm PLASTIC "T" HANDLE WRENCH	1

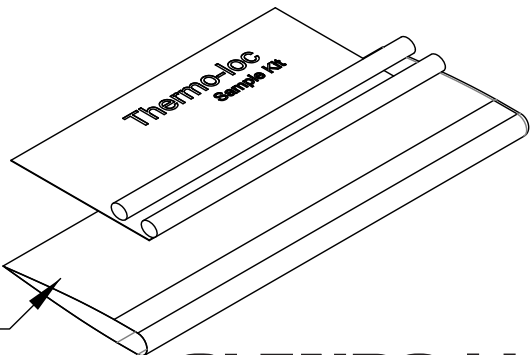

## GLENDO LLC

900 Overlander Road • Emporia, KS 66801 USA  
 800-835-3519 • 620-343-1084 • Fax: 620-343-9640  
 grs@grstools.com • grs.com  
 Last Updated: 07/02/2026