

GRS[®] BenchMate[®] QC Pin Vise

INSTRUCTIONS • #004-879

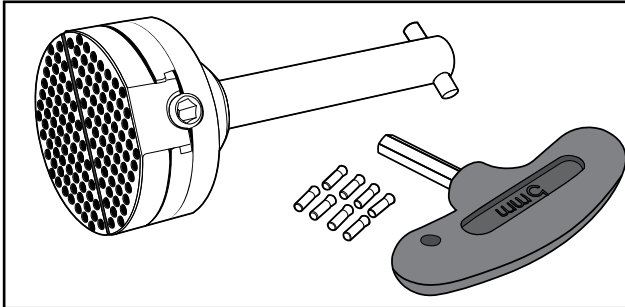

NOTE: Overtightening the jaws will cause wear and damage to the threads.

Replacement Parts List

Part #	Description	QTY
003-451	Steel Pin	4
003-452	Brass Pin	4
024-215	5 mm Hex Wrench	1

CHANGING QC FIXTURES

FIXTURE REMOVAL

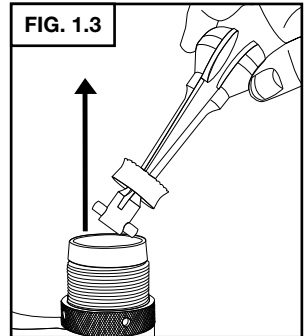
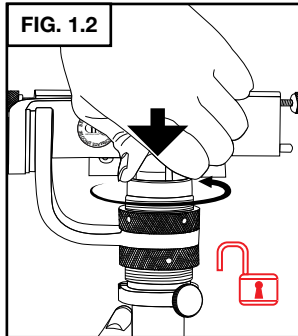
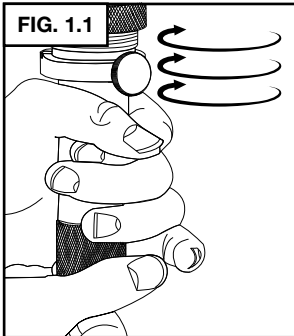

QC PIN VISE INSTALLATION

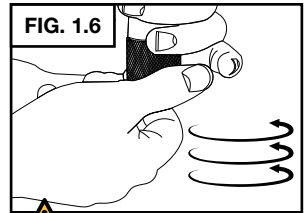
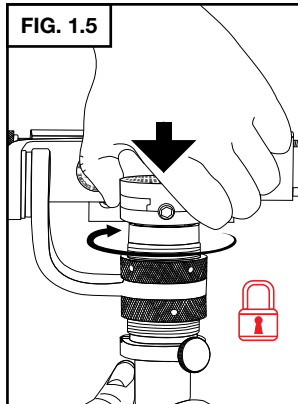
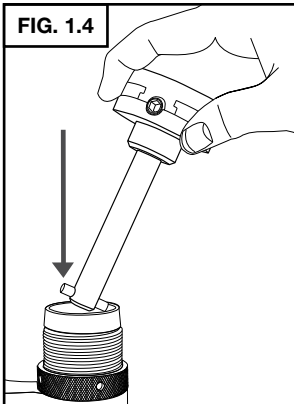

⚠ WARNING
 Make sure QuickChange fixture is seated fully before tightening with mandrel knob.
 A fixture can be ejected with force if not properly seated when tightening.

GLENDO LLC

900 Overlander Road • Emporia, KS 66801 USA
 800-835-3519 • 620-343-1084 • Fax: 620-343-9640
 grs@grstools.com • www.grstools.com
 Last Updated: 2017/10/26