

GRS® EasyGraver® Sharpening Fixture

INSTRUCTIONS • #003-700 & #003-701

1. INITIAL SETUP

RECOMMENDED SETUP

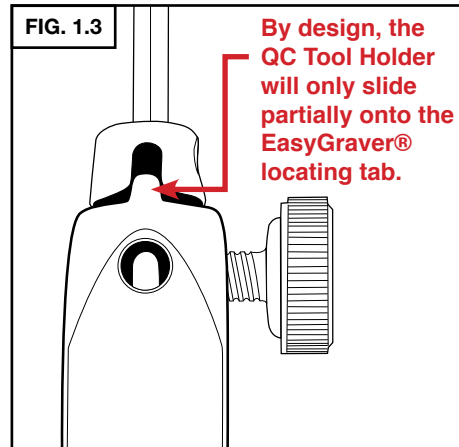
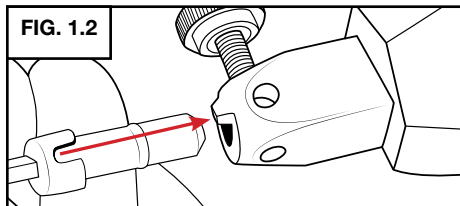
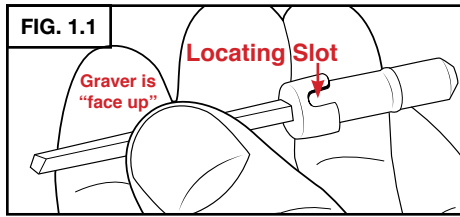

OTHER SETUP OPTIONS

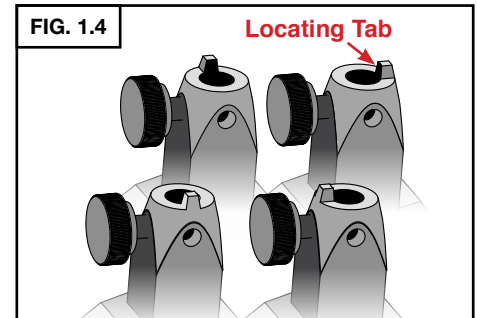

The Locating Tab may be oriented at 90° positions as needed to align the graver top with the EasyGraver Sharpening Fixture top.

2. GUIDE HOLE POSITIONS EXPLAINED

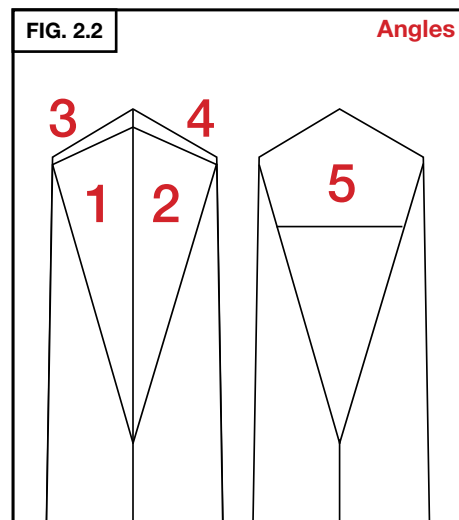
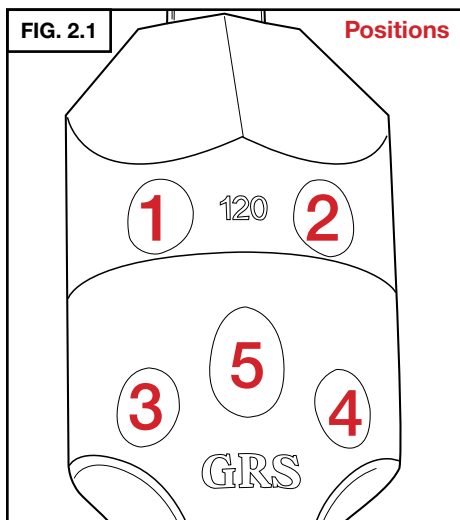

For reference, use FIG. 2.1 and FIG. 2.2. Each guide hole is numbered to correspond with the surface it produces.

- Guide Hole #1:** Reshaping Grind
- Guide Hole #2:** Reshaping Grind
- Guide Hole #3:** Heel Grind
- Guide Hole #4:** Heel Grind
- Guide Hole #5:** Face

	Product #003-700	Product #003-701
V-angle	120°	105°
Heels	~ 108°	~ 90°
Face	Slightly < 50°	Slightly < 50°

Guide Hole Positions (viewed from top of EasyGraver®).

Corresponding Graver Surfaces (viewed from graver bottom).

3. HOW TO USE

V-ANGLE RESHAPING: HOLES #1 AND #2

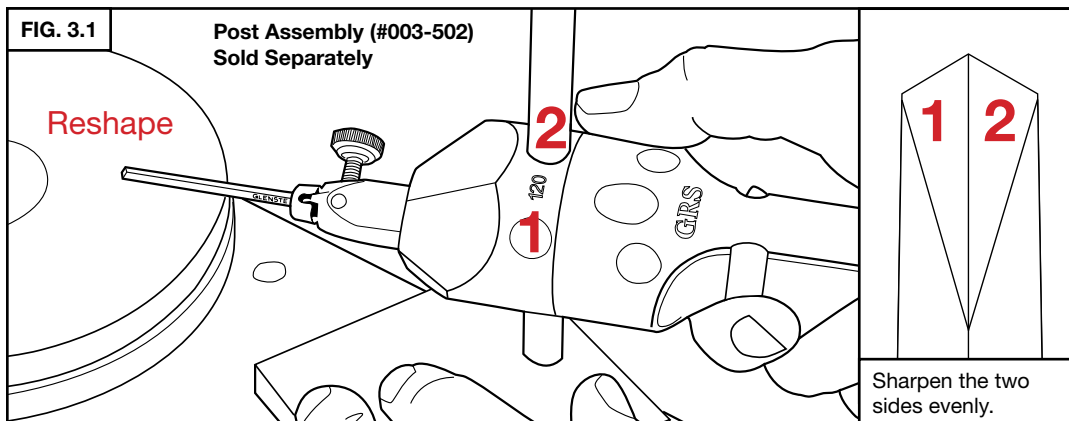

NOTE:
After the graver is shaped using holes #1 and #2, these holes may be skipped until the graver becomes short enough to need reshaping.

If the graver is removed from the QC Tool Holder and reinstalled back into that particular holder or another one, the user should always reshape the graver bottom using holes #1 and #2. *For greatest efficiency, it is always recommended to leave the graver in the same QC Tool Holder for its entire working life.*

3. HOW TO USE (continued)

HEELS: HOLES #3 AND #4

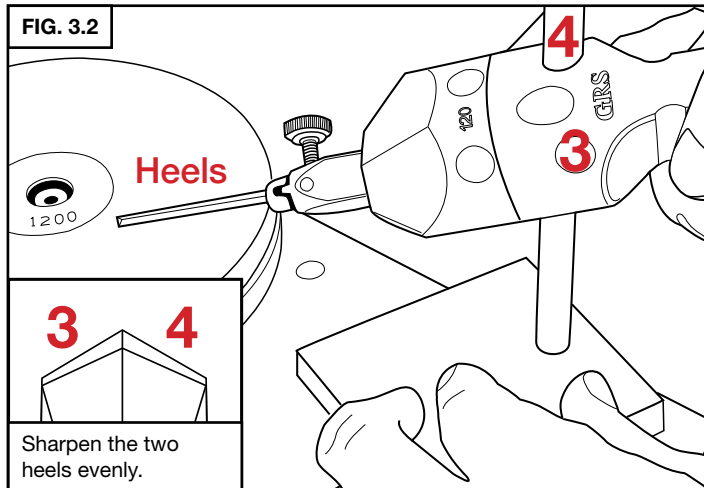

FACE: HOLE #5

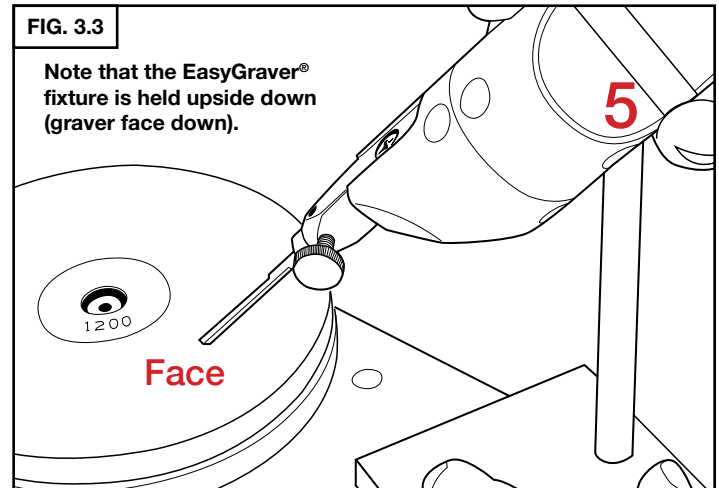

REDUCING THE GRAVER TOP

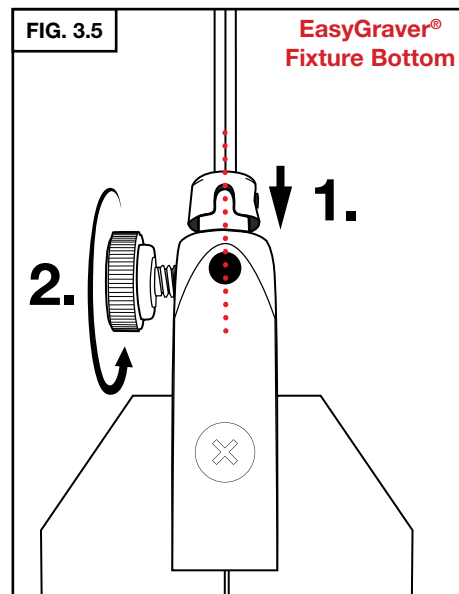
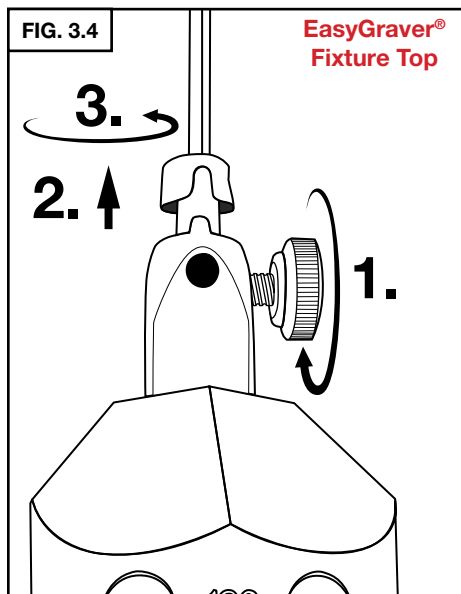

Choose an Option:

Faceted Top: See **OPTION 1 (FIG 3.8)**

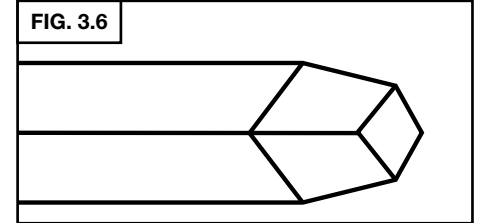

Flat Top: See **OPTION 2 (FIG 3.9-10)**

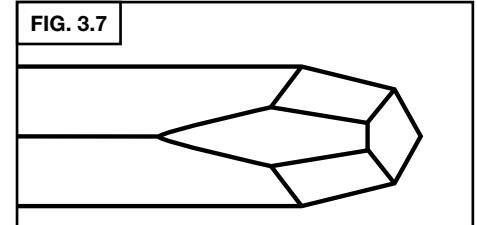

OPTION 1: Faceted Graver Top

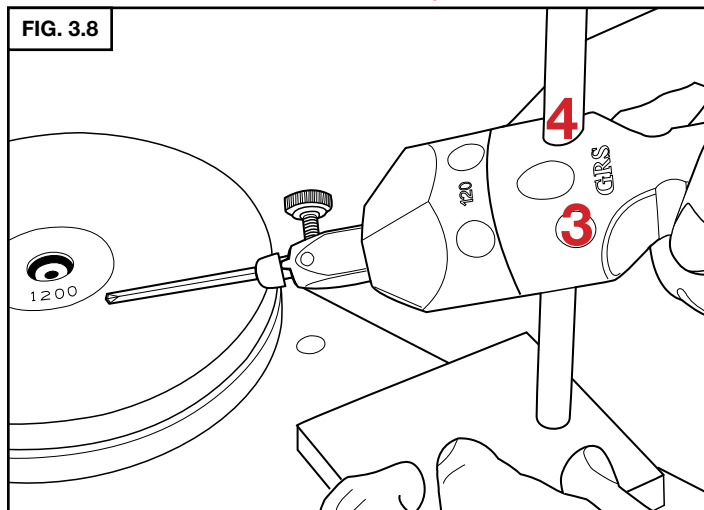

OPTION 2: Flat Graver Top

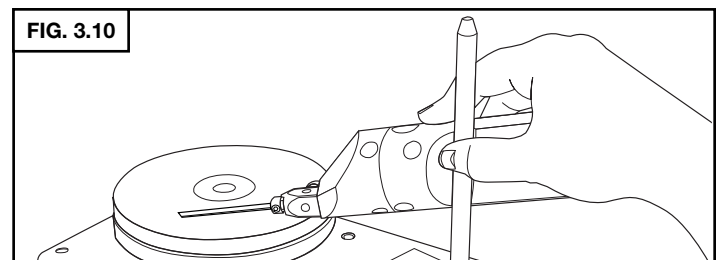
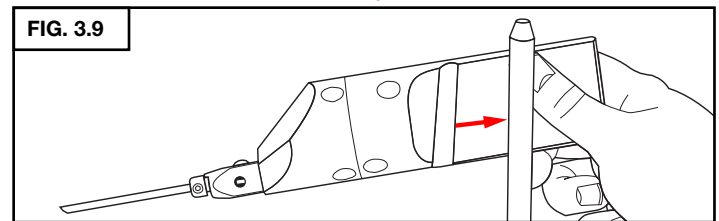

GLENDO LLC

900 Overlander Road • Emporia, KS 66801 USA
800-835-3519 • 620-343-1084 • Fax: 620-343-9640
grs@grstools.com • www.grstools.com
Last Updated: 2015-07-13