

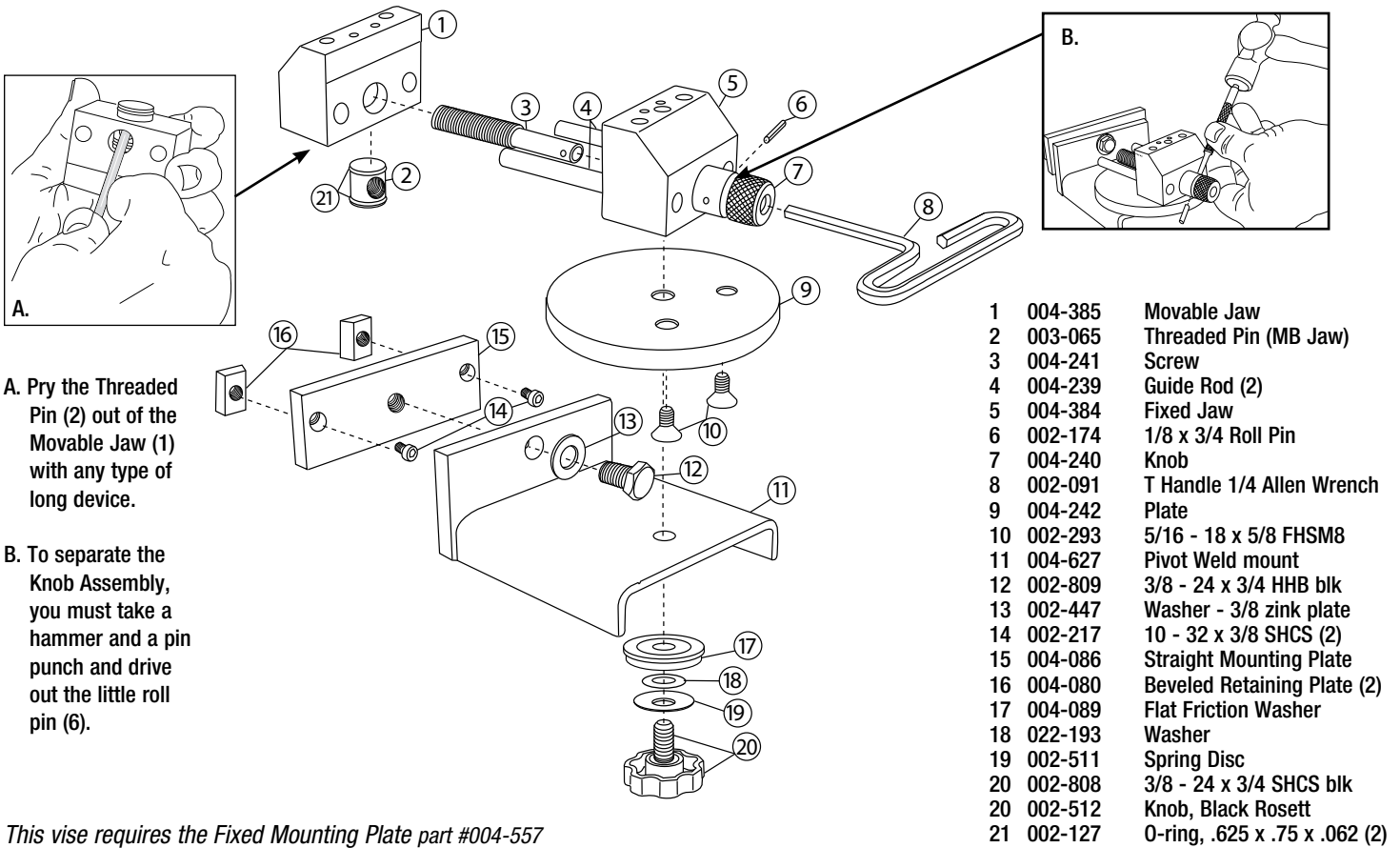

# Multi-Purpose Vice for BenchMate® System



PART #004-628

## INSTRUCTIONS FOR REPAIR AND REPLACE ONLY

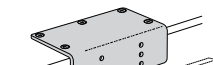
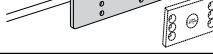
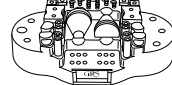

This vise requires the Fixed Mounting Plate part #004-557

### ACCESSORIES:

PART NO.		DESCRIPTION
004-559		<b>Optional Mounting Adapter</b> <i>For attaching Fixed Mounting Plate to curved or thin bench tops</i>
004-557		<b>Fixed Mounting Plate</b>
003-520MPV		<b>Attachment Set for Multi-Purpose Vise</b> <i>Includes 30-pc. attachment set, two pin plates and 4 jaw pins</i>
003-662		<b>1/4" Hex Drive Key with Knurled Aluminum Handle</b> <i>Low profile design that is handy and easy to grip. Replacement for the T-handle.</i>

CONTACT YOUR SALES REPRESENTATIVE OR VISIT GRS.COM FOR PRICING AND AVAILABILITY

# GLENDO LLC

900 Overlander Road • Emporia, KS 66801 USA  
 800-835-3519 • 620-343-1084 • Fax: 620-343-9640  
 grs@grstools.com • grs.com  
 Last Update: 11/30/2023